

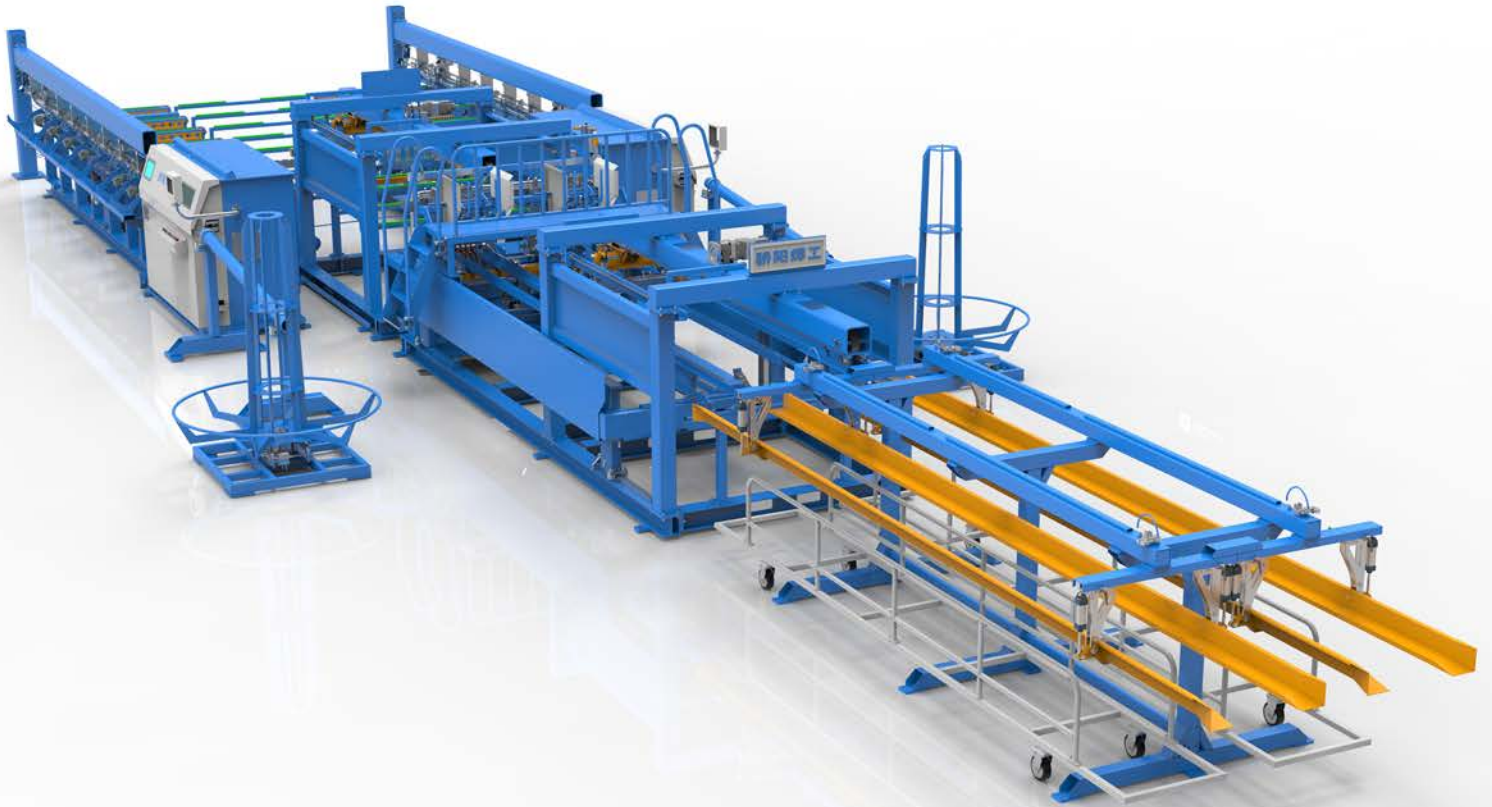

JIAOYANG
骄阳焊工

REINFORCEMENT MESH WELDING PRODUCTION LINE

GWC500CJ×2-02



Jiaoyang Welding Industries Hebei Co., Ltd.

ADD: No. 28, Wei'Er Road, Eastern Industrial Zone, Anping County, Hebei Province, China, 053600

TEL: +86-318-7063110

FAX: +86-318-7800251

web: www.jiaoyangen.net

Layout

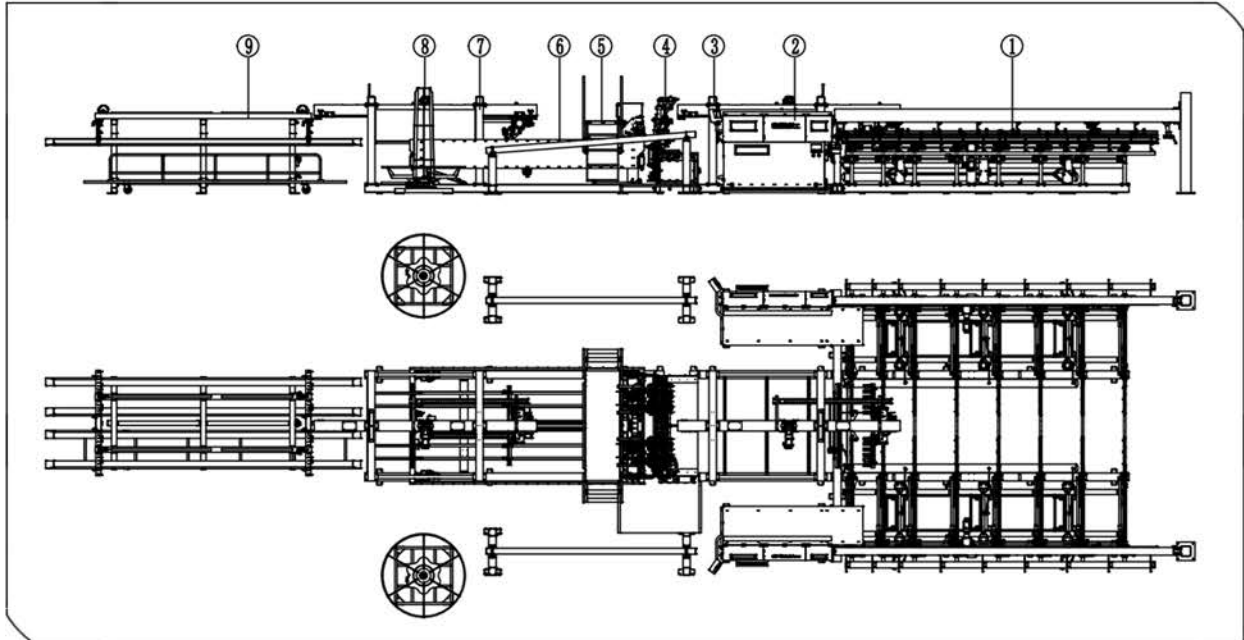

- | | |
|---------------------------------------------|-------------------------------------------|
| 1. line wire transferring and laying device | 2. wire straightening and cutting machine |
| 3. line wire feeding device | 4. welding machine |
| 5. cross wire hopper | 6. pulling device |
| 7. fast second pulling device | 8. wire payoff |
| 9. mesh fallen device | |



Technical Parameters

MODEL NO.	GWC500CJ×2-02
Width 500mm	×2
Cross wire spacing	≥50mm
Number of welding electrodes	8+8
Cross wire feeding	Pre cut /coil
Transformer	125KVA×4
Diagonal tolerance	±2mm (2m mesh length)
Wire diameter	4-8mm
Wire material	Low carbon steel wire
Welding speed	8-10panels/min (2m mesh length)
Mesh form	Mesh length ≤6m
Line wire feeding	coil
Line wire spacing	50mm

Detailed Introduction

Line wire laying device

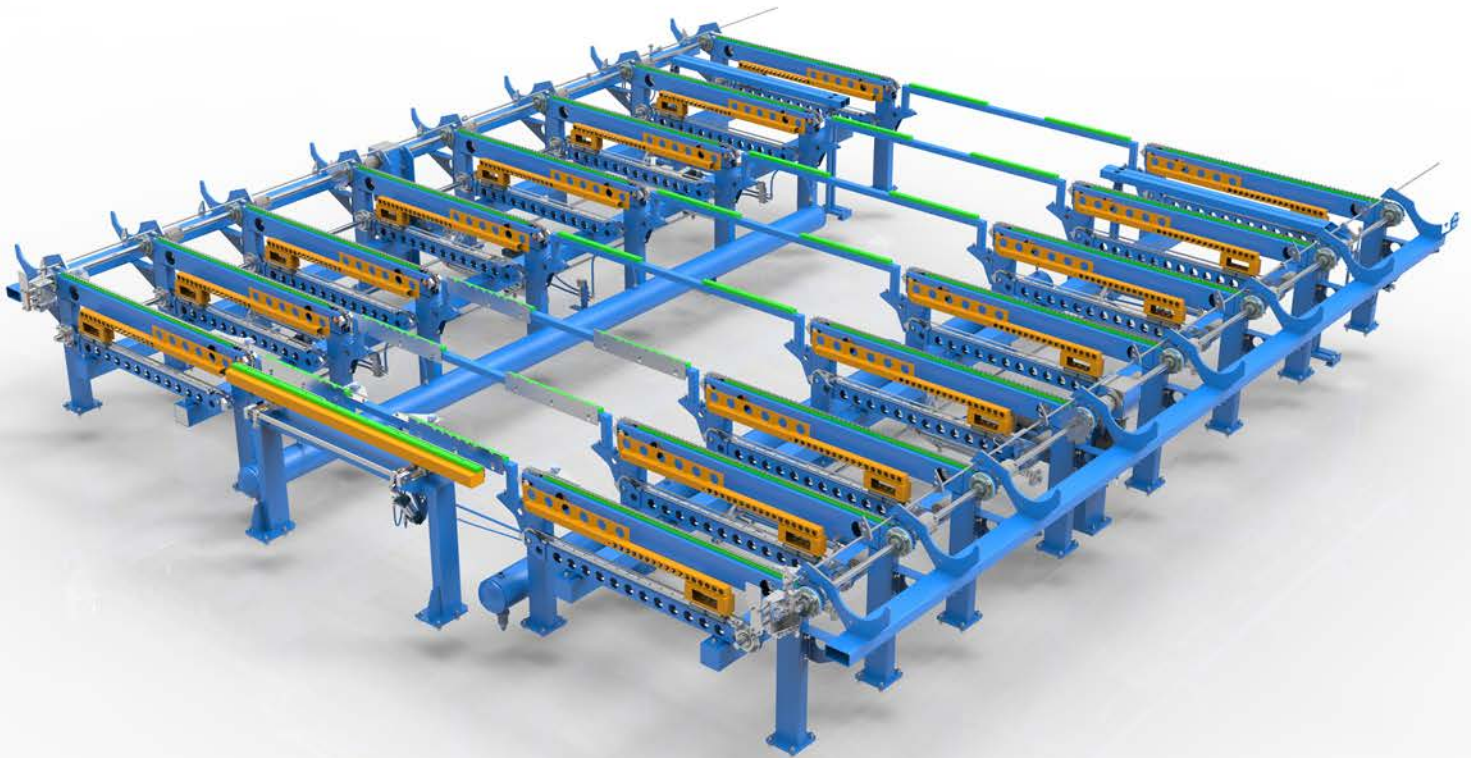

>This device will lay the pre cut line wire according the line wire spacing.

>And do the arrangement for the next feeding process.

Detailed Introduction

Line wire straightening machine



>Line wire straightening and cutting machine is integrated with welding machine. Equip 2 sets , 1 set on left side , the other set on right side.

>Pre cut line wire will be transferred to next step.

Detailed Introduction

Line wire feeding device

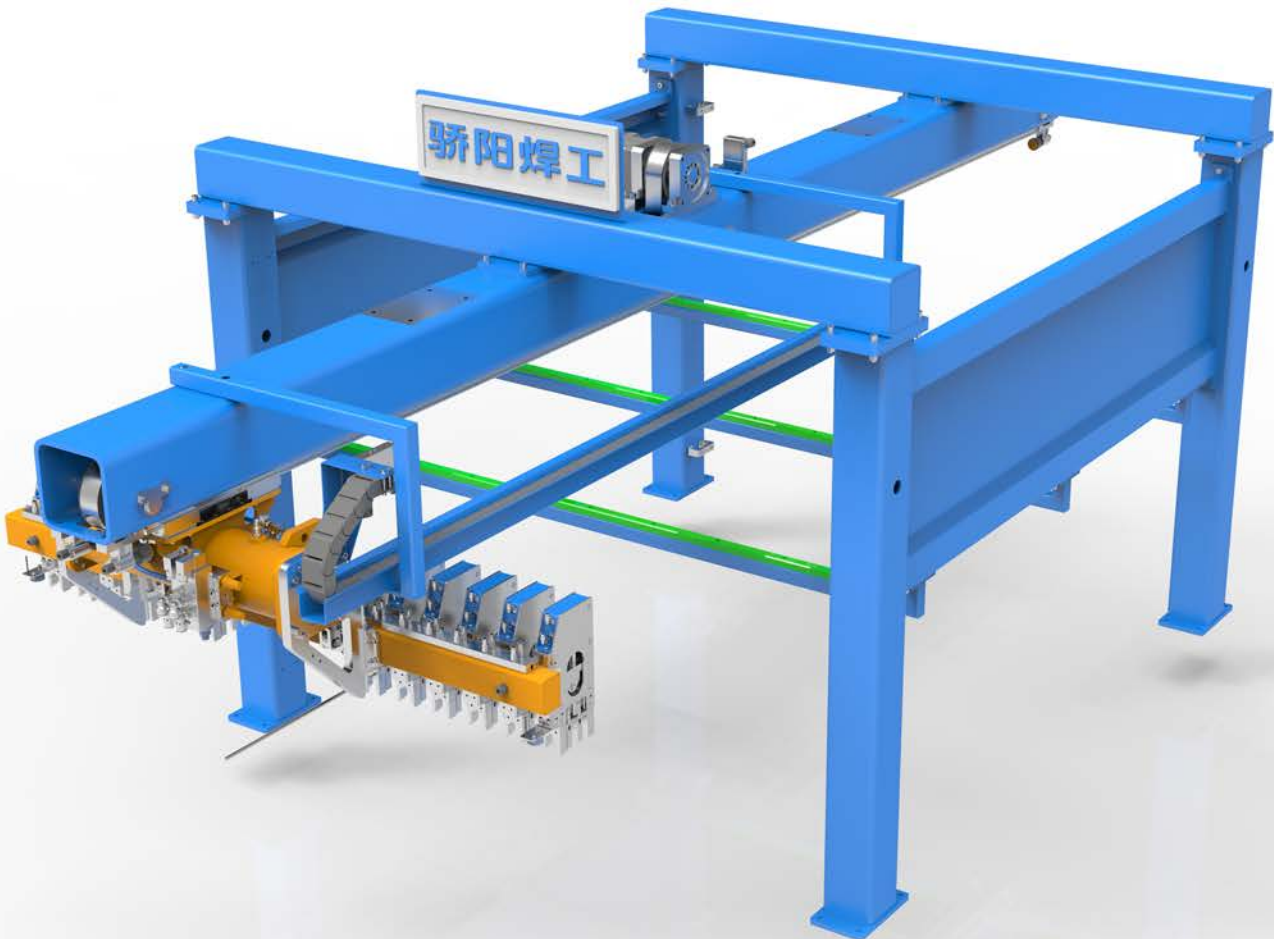

>With automatic robotic pneumatic grippers for picking up line wires from the wire delivery table and feeding the wires to the welding machine

>With picking detection device, picking fails and it will pick again automatically.

Then feeding wires to welding machine automatically.

Detailed Introduction

Welding machine

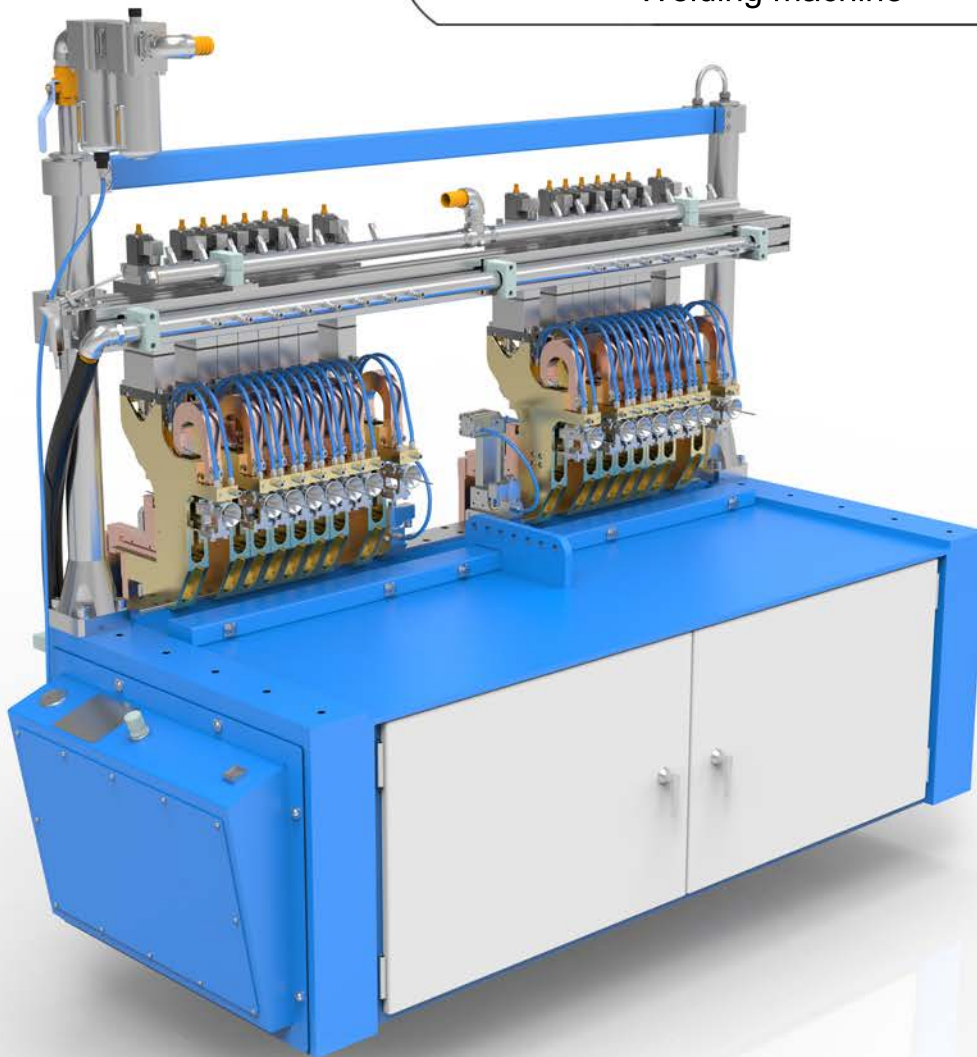

>Welding system adopt modular unit , and it will be more simple to adjust line wire spacing.

>Welding electrodes is CrZrCu with the best Hardness and conductivity .

Transformer with power 125KVA is with water cooling system, which makes use life longer.

Detailed Introduction

Cross wire hopper



>Load about 150kgs wire

>Wire drops driven by step motor .

>It is installed on the pulling device,which can away from the welding machine.

It will more convenient to do repairing and adjustment.

Detailed Introduction

Mesh pulling device

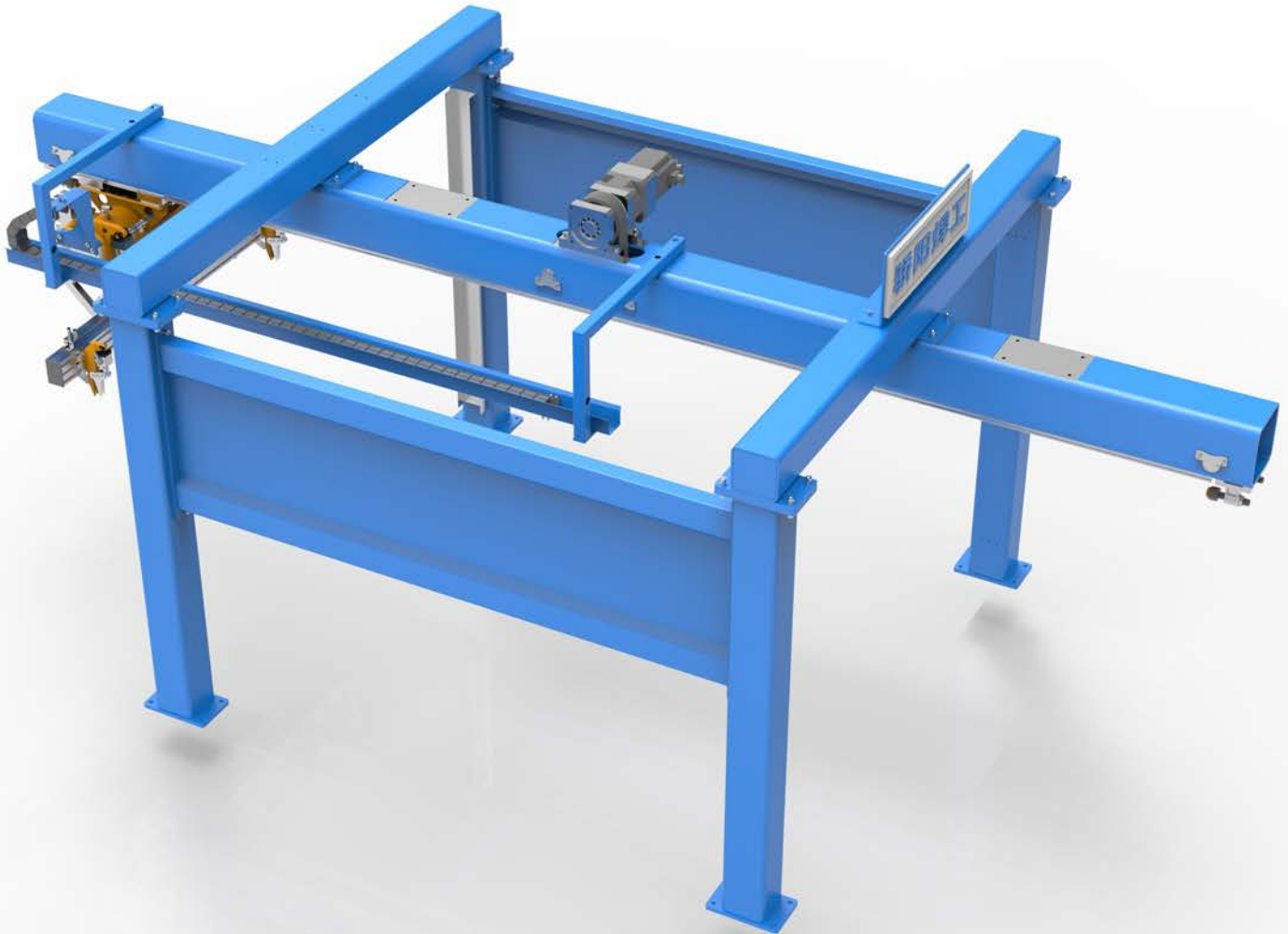

>After mesh welded, it will be pulled .

>out ,driven by servo motor with precise size.

Detailed Introduction

Mesh fallen device

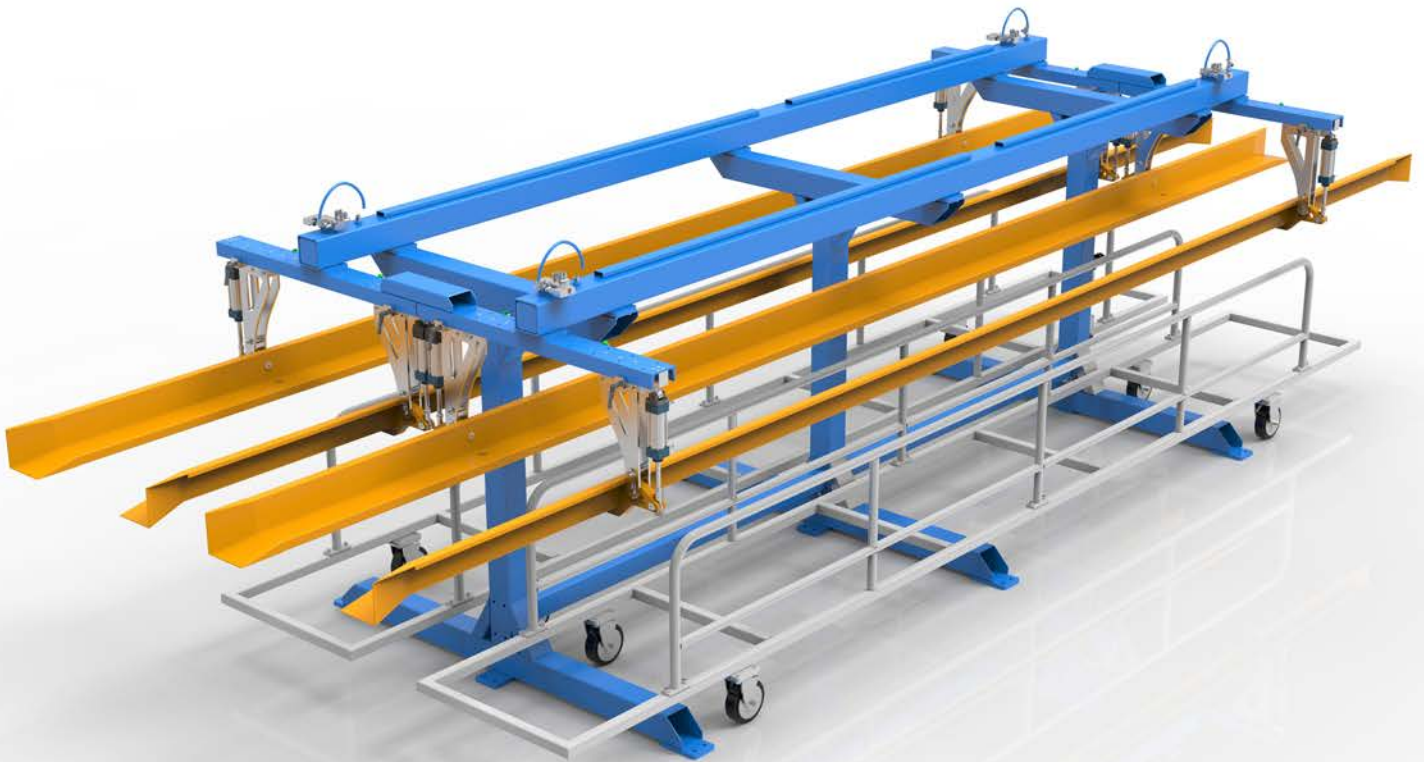

>Max mesh panel length is at 6m

>It is composed of dustpan type supporting plates both sides and C-type frame

>Receiving structure can be feely adjusted according the mesh width.



JIAOYANG
骄阳焊工

Jiaoyang Welding Industries Hebei Co., Ltd.

TEL: +86-318-7063110

E-mail:joy@jiaoyangen.net

ADD: No. 28, Wei'Er Road, Eastern Industrial
Zone, Anping County, Hebei Province ,
China ,053600

FAX:+86-318-7800251

web:www.jiaoyangen.net