

FULL AUTO. 2D DOUBLE WIRE FENCE WELDING LINE

GWC3000CH-03

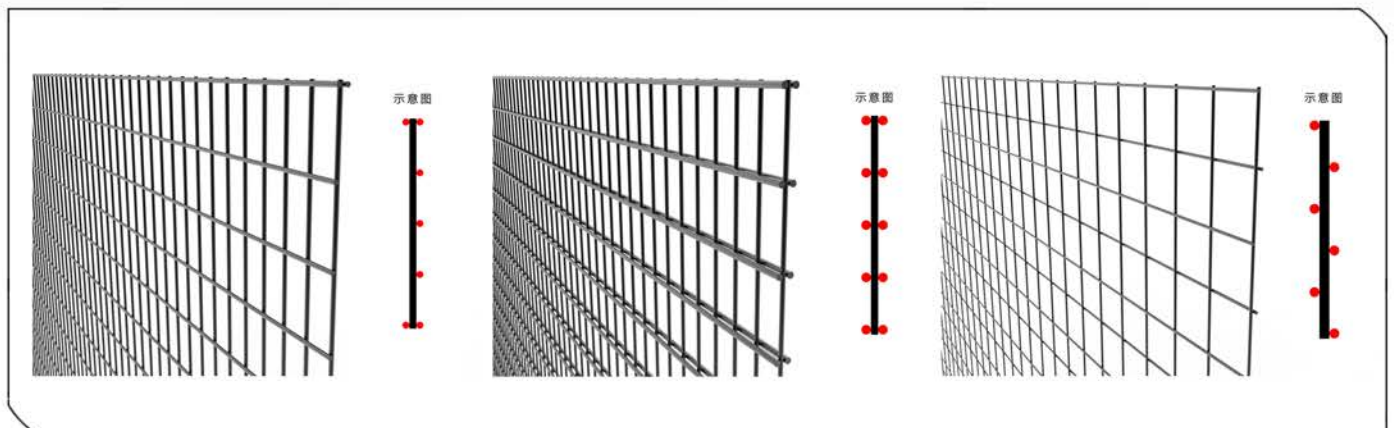
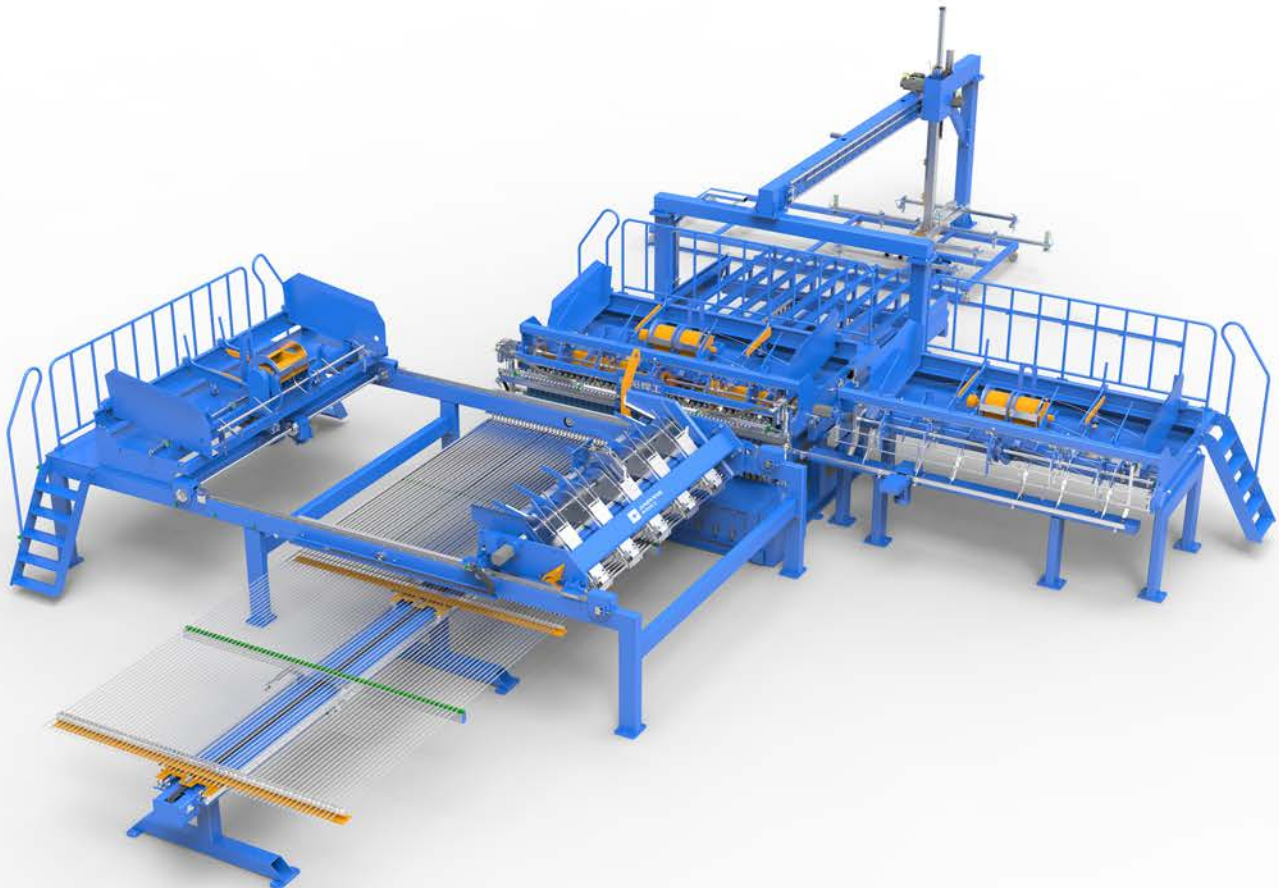

Jiaoyang Welding Industries Hebei Co., Ltd.

ADD: No. 28, Wire Road, Eastern Industrial Zone, Anping County, Hebei Province, China, 053600

TEL: +86-318-7063110

FAX: +86-318-7800251

web: www.jiaoyang.net

Layout

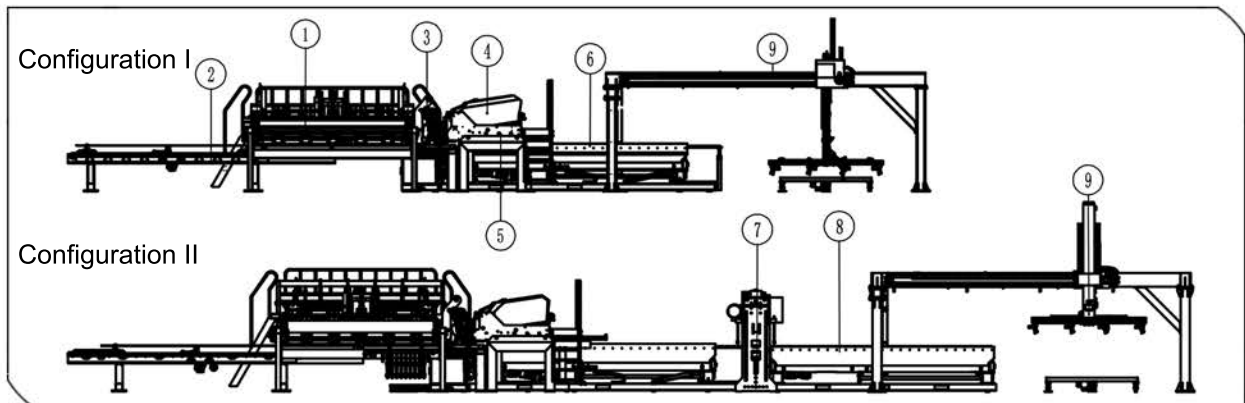

- ① line wire align&sending device
- ② line wire pushing device
- ③ Main welding machine
- ④ Cross wire pre-loading magazine (top)
- ⑤ Cross wire pre-loading magazine (bottom)
- ⑥ round-trip mesh pull
- ⑦ mesh grab automatically (to position)
- ⑧
- ⑨

basic parameter

GWC3000CH-03			
Max.mesh width	3000mm	Cross wire diameter	3.0-8.0mm
Mesh length	≤3000mm	No.electrodes	61pcs
Cross wire space	200mm Stepless adjustment	Welding speed	60times/min
Line wire space	50mm	Line wire diameter	5.0-6.0mm
Covering space	19819×11392×4200mm		
Welding transformer	Intermediate frequency 350KVA×9sets		

Description

Line wire align device

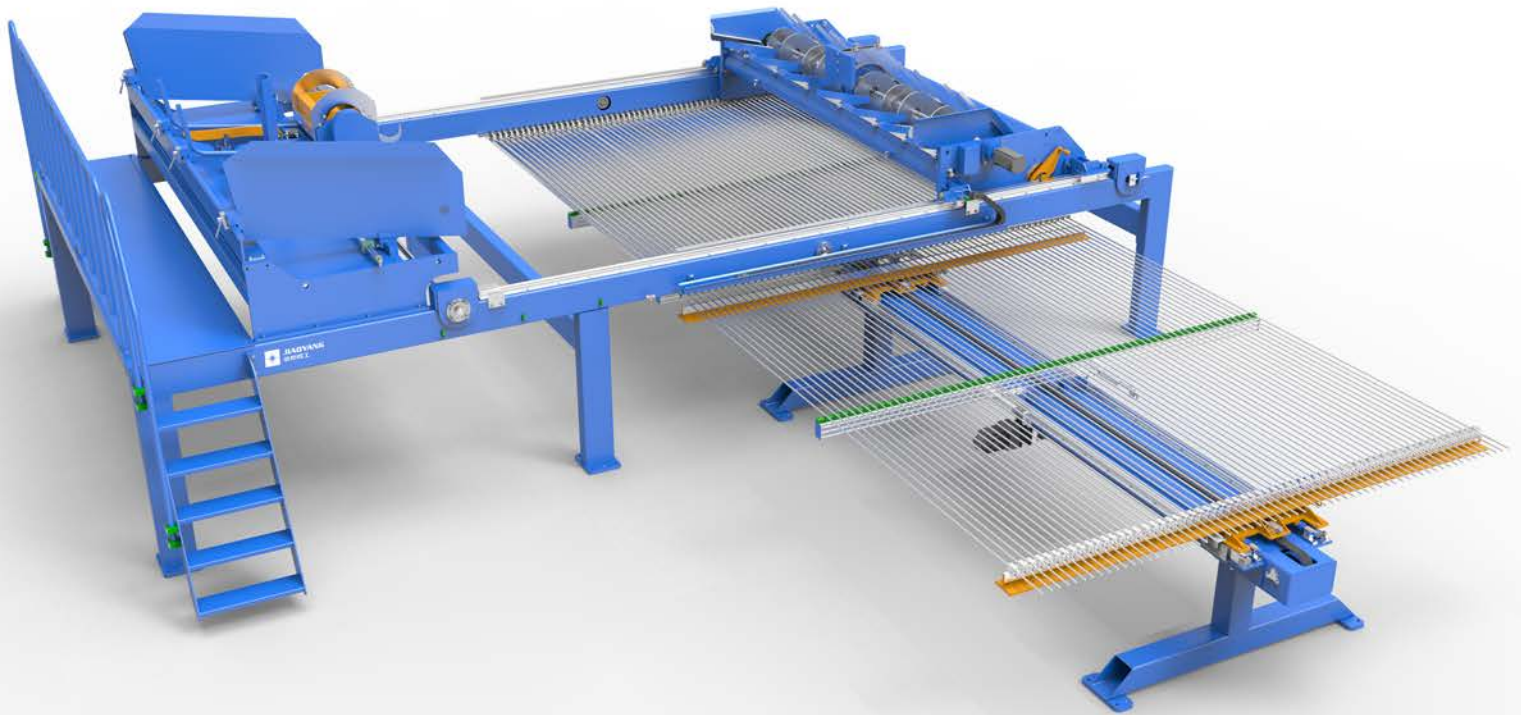

>The line wires are automatically arranged and pushed together and fed automatically, saving labor.

>The line wire hopper can load 1.5 tons raw materials, the align speed is 120 pcs / min, and the length of raw materials is 650mm-3000mm.

Description

Main welding machine

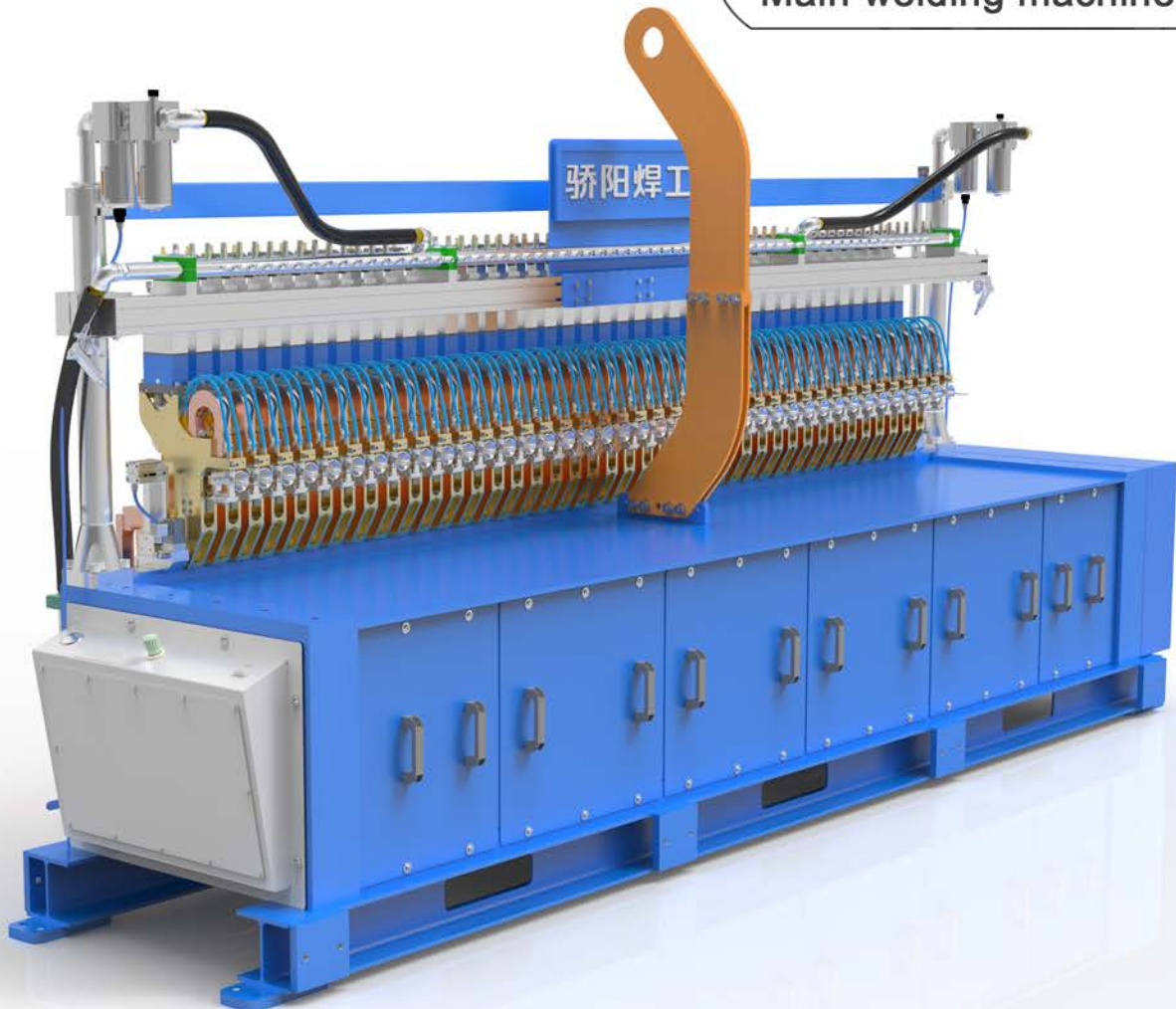

>Pneumatic main welding machine adopts quadruple force one-way acting cylinder for welding, saving 30% compression capacity and fast speed.

>The cross wire positioning adopts pneumatic aligning and two sets of detection devices, and the edge is $\leq 1\text{mm}$, ensure the edge is neat.

>The line wire positioning adopts V-shaped steel mold threading assembly, which can adapt to the change of wire diameter.

Description

Cross wire pre-loading magazine

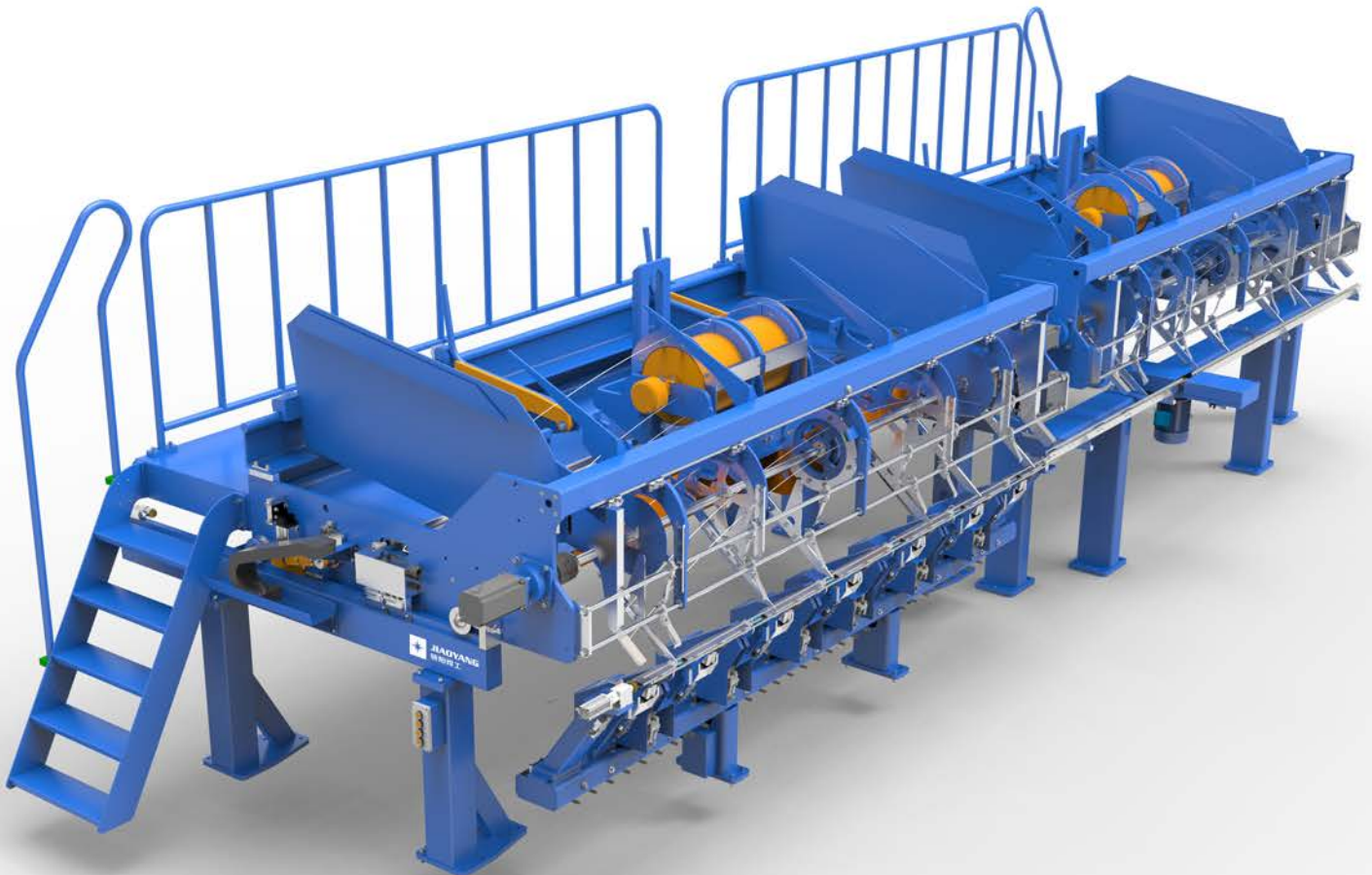

>Two cross wire hoppers are distributed on the top and below of the line wire to realize the simultaneous supply and welding of two cross wires.

>The hopper can store 1.5 tons to improve production efficiency.

Description

Round-trip mesh pull



>Servo motor control with high-precision rack.

>The stroke is 4.5m, saving factory space.

>The pulling frame can be moved, which is convenient for operation and maintenance.

Description

Automatic grab & stack



>Automatic mesh grabbing and stacking

>The stacking height is 500mm / stack.

>There are two position can loading the finished mesh stack,ensure that the machine can work continuously.



JIAOYANG
骄阳焊工

Jiaoyang Welding Industries Hebei Co., Ltd.

TEL: +86-318-7063110

E-mail:joy@jiaoyangen.net

ADD: No. 28, Wire Road, Eastern Industrial
Zone, Anping County, Hebei Province ,
China ,053600

FAX:+86-318-7800251

web:www.jiaoyangen.net