

瞬间成就永恒  
Instant makes eternity



## Company Profile >

JIAOYANG WELDING INDUSTRIES HEBEI CO.,LTD(hereinafter referred to as "JIAOYANG" ) is located in the well known hometown of wire mesh--Anping County, Hebei Province, Established in 1988 and over 30 years of tempering, under the strategic planing of "Based on the mesh industry and Serving the society", the company implement a modern management system combining industrialization,informationization, and standardization, and becomes to a welded mesh manufacturer that integrating R&D, design, manufacturing, sales and service, which has been the domestic technology R&D enterprise that specializing studies of wire mesh and steel bar resistance welding technology and equipment.

Combining the characteristics of various industries at domestic and overseas, JIAOYANG has successively launched series of welded mesh equipments for different industries, such as special welding machines for livestock poultry mesh, special welding machines for concrete reinforcement, steel truss machines, special welding machines for industrial storage shelf, fences, etc., which are highly appreciated by the users.

With its strong R&D strength, JIAOYANG has built a provincial A-level industrial enterprise on R&D structure and technology center, and has obtained more than 150 valid patents and participated in the formulation of a number of industry standards related to steel bar processing. Company products have sold to 156 cities in 29 provinces in China and 86 countries & regions around the world. In order to further improve the user's product experience, the company has established the "Jiaoyang Customized Factory", which can provide the personalized and customized solutions according to users' mesh welding needs.

With its advanced manufacturing technology and modern management methods, JIAOYANG creates an excellent brand and assists the rapid development of the welded mesh industry, while based on China and toward to the world, it pursues a more outstanding development goal with a leap-forward thinking, and strives to do excellent job on intelligent welded wire mesh equipments manufacturing business.



Scan QR code, to know about Jiaoyang



On the basis of independence, JIAOYANG continuously improves, accumulates bit by bit, technological innovation, and management innovation, and uses excellent products and services to meet the different needs of customers.

# JIAOYANG 骄阳焊工

## CUSTOMIZED FACTORY

Supply according to your needs, personalized development.

# POULTRY CAGES MESH WELDING LINE /GWCA1-02/03

**Standard Configuration** Wire payoff, Main welding machine, cross wire hopper, pulling mesh, mesh cutting machine, Mesh falling cart

**Optional Configuration** Cross wire edge cutter  spot welder/Slant welder  slitting machine  Line wire sensor  Mesh cutter without edges  Slanting or swing device   
short wire welding device  Line wire straightening roller+frame

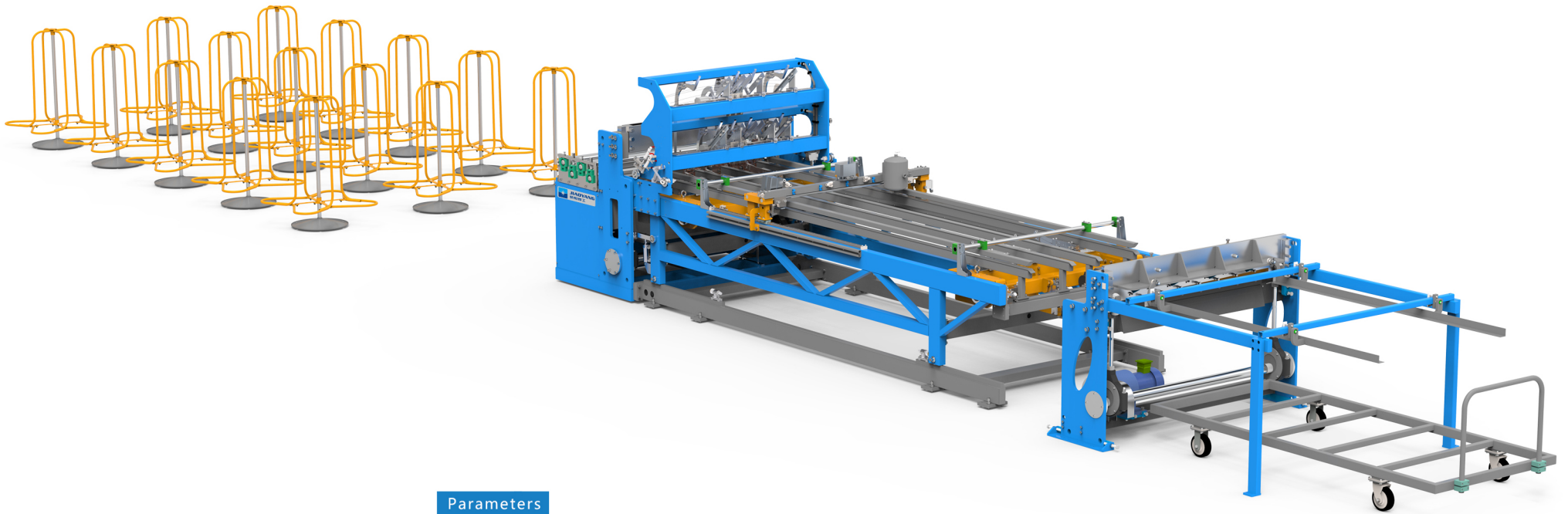

## Parameters

Mesh width	1200/1600mm	Cross wire space	≥25mm
Number of electrodes	16/32	Cross wire feeding	precut wire≥400mm
Transformer	125KVA×3/4	Tolerance of diagonal line	±2mm
Wire diameter	2-3.5mm	Welding material	low carbon steel wire, galvanized wire
Welding speed	60-80times/min	Finished mesh	Panel, sheet
Line wire feeding	Coil	Line wire space	50-200mm



Scan QR code, to watch product working video

# BARRIER MESH WELDING LINE /GWC395ZY-04

**Standard Configuration** Wire payoff, Wire storage device+straightening roller, Double layer cross wire

**Optional Configuration** Mesh output platform (Equipped with mesh cutting machine)  Simple water cooling chiller

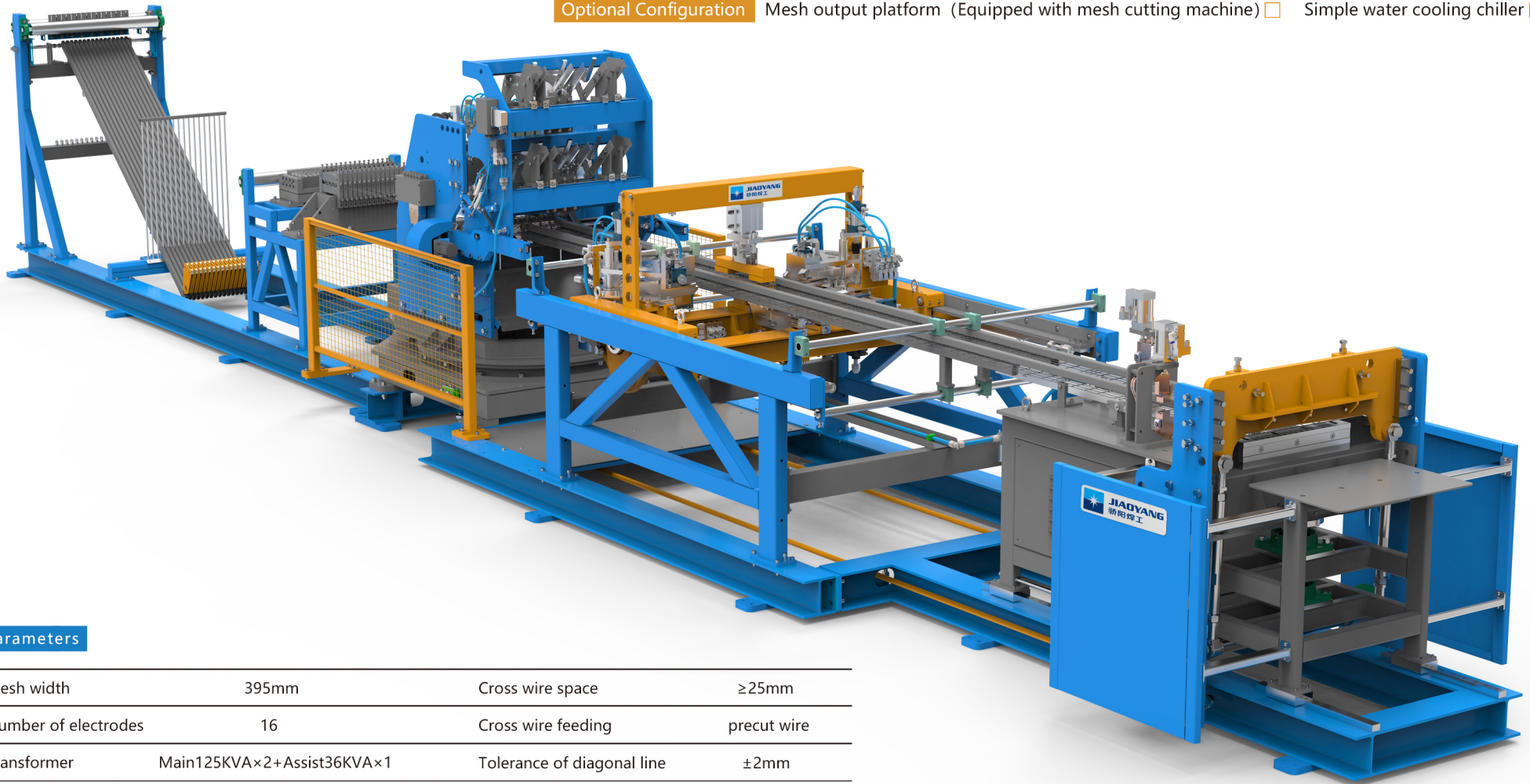

## Parameters

Mesh width	395mm	Cross wire space	≥25mm
Number of electrodes	16	Cross wire feeding	precut wire
Transformer	Main125KVA×2+Assist36KVA×1	Tolerance of diagonal line	±2mm
Wire diameter	2-3mm	Welding material	low carbon steel wire
Welding speed	6-8pcs/min	Finished mesh	Panel, sheet
Line wire feeding	Coil	Line wire space	≥23mm



Scan QR code, to watch product working video

# POULTRY CAGE DOOR WELDING LINE /GWC190/227ZY-01

**Standard Configuration** GWC190ZY-01: Wire payoff, Wire storage shelf, Straightening roller, Wire holder, Cross wire straightening and feeding system, Main welding machine, Auto.bending, Auto.cutting, Mesh collection frame  
 GWC227ZY-01: Wire payoff, Main welding machine, Auto.bending, Auto.cutting, Mesh collection frame

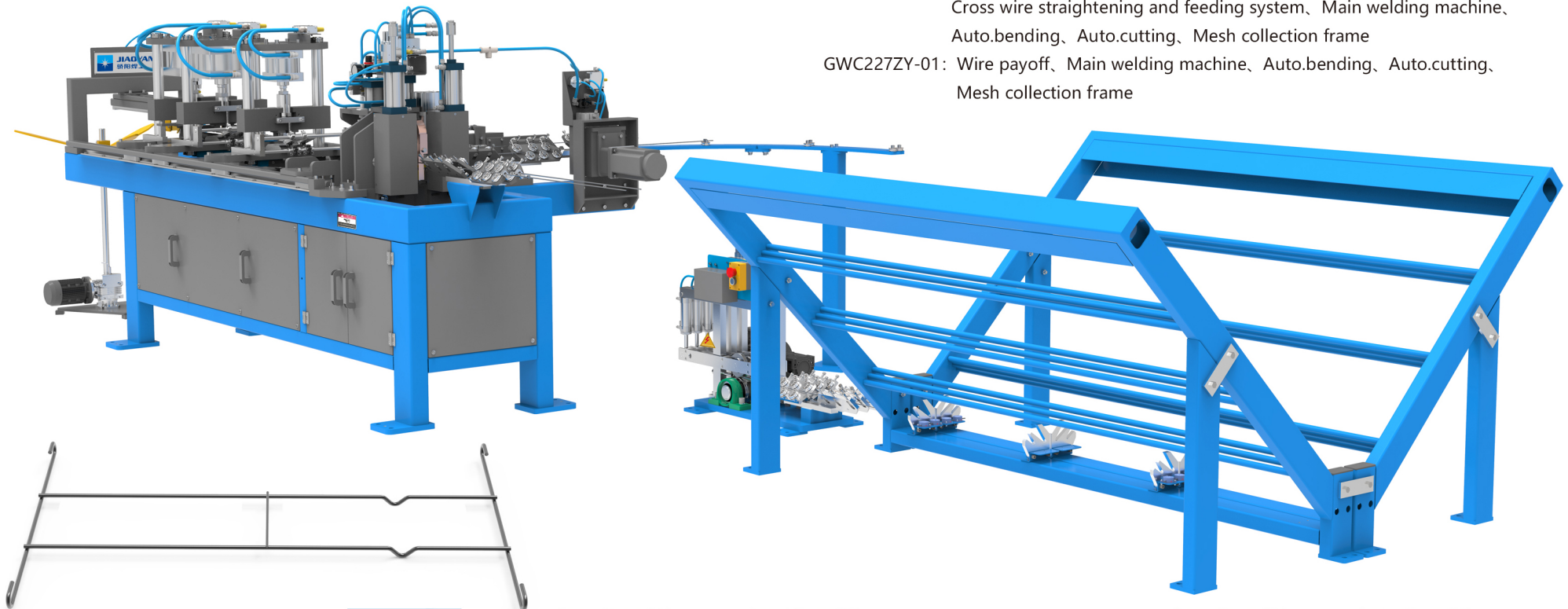

Parameters	GWC192ZY-01	GWC227ZY-01	GWC192ZY-01	GWC227ZY-01
Mesh width	192mm	227mm	Cross wire space	400-490mm
Number of electrodes	2sets(for big wire) 2sets(for small wire)	3sets(for big wire) 3sets(for small wire)	Cross wire feeding	Coil
Transformer	36KVA×2	75×1+56×1KVA	Tolerance of diagonal line	±1mm
Wire diameter	4.5+4.0+2.5	5.0+4.5+2.5	Welding material	low carbon steel wire,galvanized wire
Welding speed	10s/pc	10s/pc	Finished mesh	Panel, sheet
Line wire feeding	Coil	Coil	Line wire space	65mm
Hook inner dia	R3,25mm	R4,25mm	Hook position	110mm
				No



Scan QR code, to watch product working video

# POULTRY CAGE DOOR WELDING LINE /GWC270ZY-03

Standard Configuration Wire payoff, Main welding machine, Auto.bending, Auto.cutting, Mesh collection frame

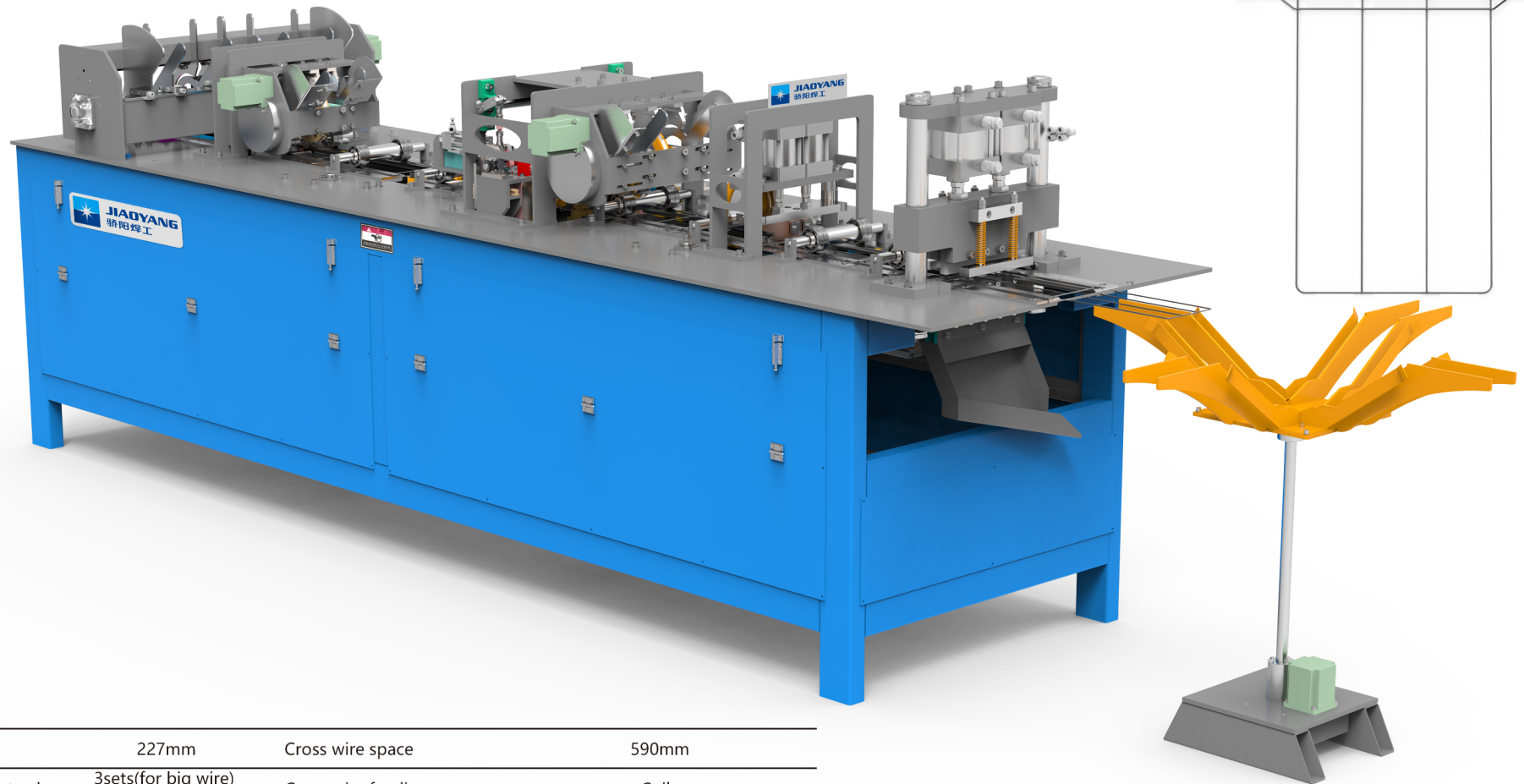

## Parameters

Mesh width	227mm	Cross wire space	590mm
Number of electrodes	3sets(for big wire) 3sets(for small wire)	Cross wire feeding	Coil
Transformer	75×1+56×1KVA	Tolerance of diagonal line	±1mm
Wire diameter	5.0+4.5+2.5	Welding material	low carbon steel wire,galvanized wire
Welding speed	6-10s/pc	Hook inner dia	R4,25mm
Line wire feeding	Coil	Line wire space	55+55mm



Scan QR code, to watch product working video

# POULTRY CAGE DOOR WELDING LINE /GWC350ZY-02

- Standard Configuration** Wire payoff, Line wire feeding system, cross wire feeding system, Main welding machine, Auto.bending, Auto.cutting, Mesh collection frame
- Optional Configuration** Water cooling chiller

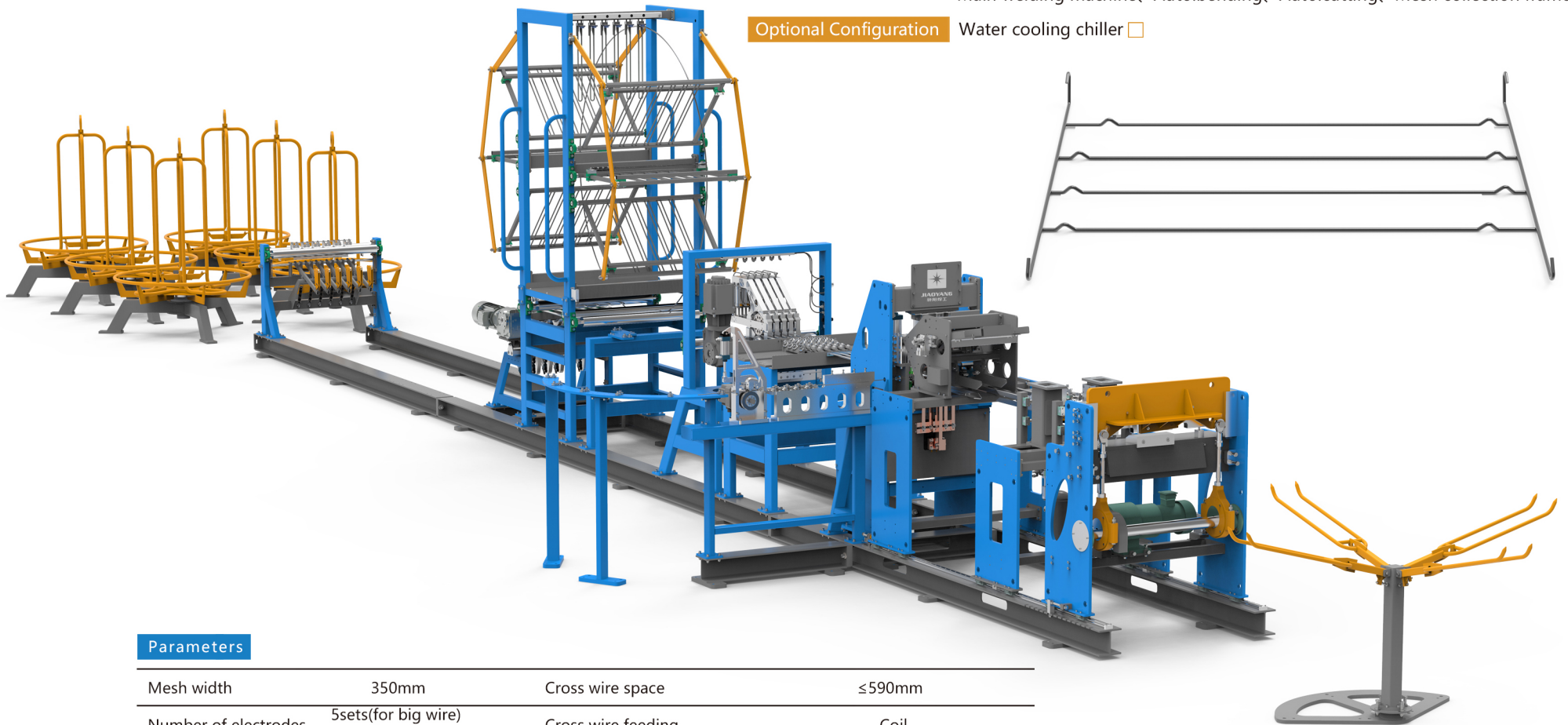

## Parameters

Mesh width	350mm	Cross wire space	≤590mm
Number of electrodes	5sets(for big wire) 5sets(for small wire)	Cross wire feeding	Coil
Transformer	125KVA×1	Tolerance of diagonal line	±1mm
Wire diameter	Line5.0+Cross4.5	Welding material	low carbon steel wire,galvanized wire
Welding speed	10s/pc	Hook inner dia	R4,25mm
Line wire feeding	Coil	Line wire space	55+55mm



Scan QR code, to watch product working video



# POULTRY CAGE SPOT WELDER/SLANT WELDER/DBH-01&XBH-01

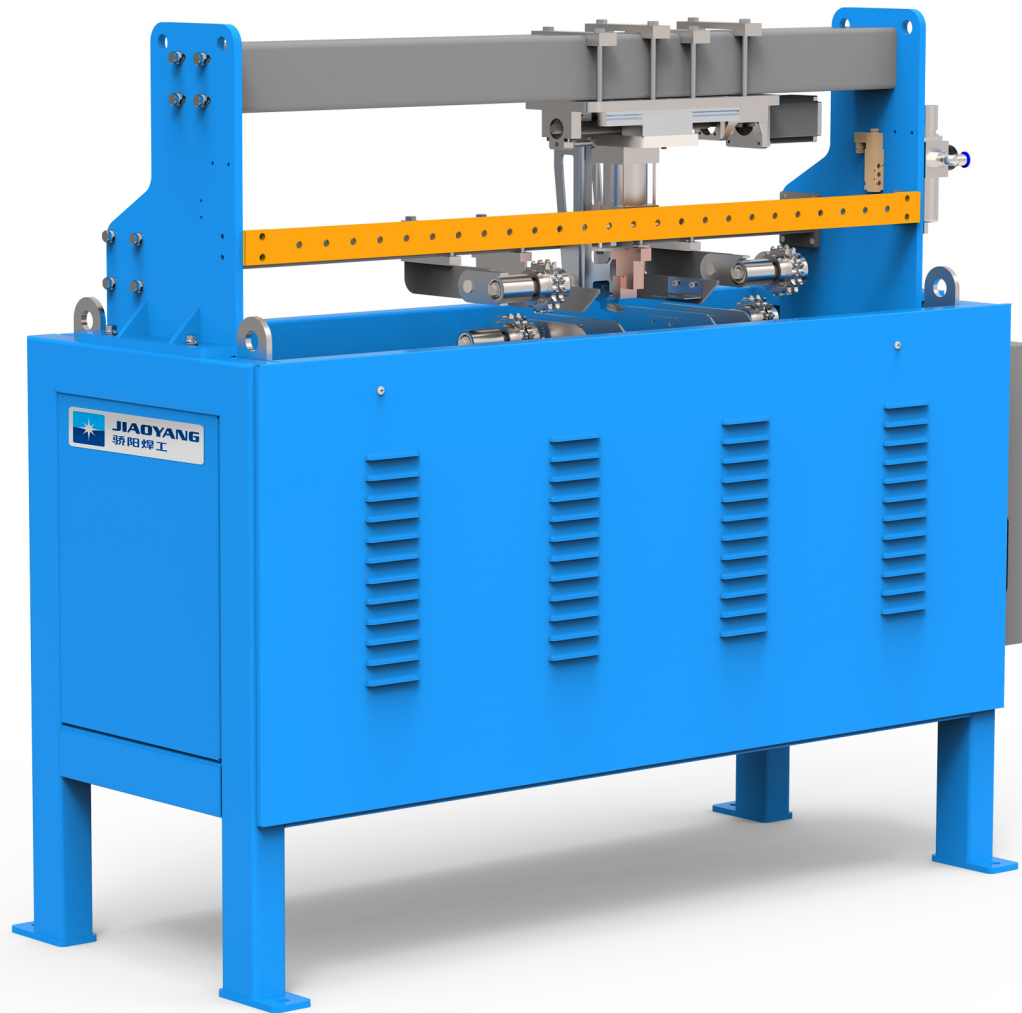

Parameters		Spot welder/DBH-01	
Wire diameter	2-3.5mm	Mesh width	1200/1600mm
Pressure	Pneumatic	Welding wire quantity	1pc
Transformer	36KVx1	Power supply	380V50HZ

Parameters		Slant welder/XBH-01	
Wire diameter	2-3mm	Mesh width	1200/1600mm
Welding length	80-100mm	Welding wire quantity	2pcs
Transformer	36KVx1	Power supply	380V50HZ

# WIRE STRAIGHTENING AND CUTTING MACHINE GTQ2/3.5&GTQ3/6&GTQ4/8&GTQ6/12

GTQ2/3.5

Optional Configuration Normal wire payoff  Brake payoff  Power payoff   
Lift-up pay-off+guiding

GTQ3/6&GTQ4/8&GTQ6/12

Optional Configuration Power payoff  Tungsten steel wire gripping wheel   
Tungsten steel wire straight die  Lubrication device



Parameters	GTQ2/3.5	GTQ3/6	GTQ4/8	GTQ6/12
Wire diameter	2-3.5mm	3-6mm	4-8mm	6-12mm
Working speed	60-80m/min	110m/min	110m/min	130m/min
Wire straightness	≤2mm/m	≤2mm/m	≤2mm/m	≤2mm/m
Wire type	coil	coil	coil	coil
Cutting length	0.3-3m	0.5-6m	0.5-6m	0.8-6m
Cutting method	Eccentric shear	Servo cutting	Servo cutting	Servo cutting
Wire material	Low carbon steel wire,galvanized wire			
Wire pressure	Mechanical	Pneumatic	Pneumatic	Pneumatic
Cutting tolerance	±0.2mm/m	±0.2mm/m	±0.2mm/m	±0.2mm/m
Total power capacity	4KW	10.5KW	18KW	34KW
Power supply	380V50HZ	3P380V50HZ	3P380V50HZ	3P380V50HZ



Scan QR code, to watch product working video



**河北骄阳焊工有限公司**  
**Jiaoyang welding industries hebei co.,ltd**

Add: NO.28 WEIER ROAD , EASTERN INDUSTRIAL ZONE,ANPING COUNTY,  
HEBEI PROVINCE,CHINA,053600

Tel: +86-318-7063110

Fax: +86-318-7800251

E-mail: joy@jiaoyangen.net

地址：河北省安平县工业园东区纬二路28号

营销部

电话：0318-7063097

传真：0318-7800251

售后服务

电话：0318-8065001

0318-7063093

网址：www.jiaoyang.net

由于我们的产品不断改进创新，因此产品结构参数及颜色可能与本样本有出入，请以实际产品为准，敬请谅解。

