

**工业网焊机**  
Welding machine for Industrial mesh



## Company Profile >

JIAOYANG WELDING INDUSTRIES HEBEI CO.,LTD(hereinafter referred to as "JIAOYANG" ) is located in the well known hometown of wire mesh--Anping County, Hebei Province, Established in 1988 and over 30 years of tempering, under the strategic planing of "Based on the mesh industry and Serving the society", the company implement a modern management system combining industrialization,informationization, and standardization, and becomes to a welded mesh manufacturer that integrating R&D, design, manufacturing, sales and service, which has been the domestic technology R&D enterprise that specializing studies of wire mesh and steel bar resistance welding technology and equipment.

Combining the characteristics of various industries at domestic and overseas, JIAOYANG has successively launched series of welded mesh equipments for different industries, such as special welding machines for livestock poultry mesh, special welding machines for concrete reinforcement, steel truss machines, special welding machines for industrial storage shelf, fences, etc., which are highly appreciated by the users.

With its strong R&D strength, JIAOYANG has built a provincial A-level industrial enterprise on R&D structure and technology center, and has obtained more than 150 valid patents and participated in the formulation of a number of industry standards related to steel bar processing. Company products have sold to 156 cities in 29 provinces in China and 86 countries & regions around the world. In order to further improve the user's product experience, the company has established the "Jiaoyang Customized Factory", which can provide the personalized and customized solutions according to users' mesh welding needs.

With its advanced manufacturing technology and modern management methods, JIAOYANG creates an excellent brand and assists the rapid development of the welded mesh industry, while based on China and toward to the world, it pursues a more outstanding development goal with a leap-forward thinking, and strives to do excellent job on intelligent welded wire mesh equipments manufacturing business.



Scan QR code, to know about Jiaoyang

# JIAOYANG



**JIAOYANG**  
骄阳焊工

# CUSTOMIZED FACTORY

Supply according to your needs, personalized development.



On the basis of independence, JIAOYANG continuously improves, accumulates bit by bit, technological innovation, and management innovation, and uses excellent products and services to meet the different needs of customers.



Scan QR code, to watch product working video

# FULL AUTOMATIC FENCE MESH WELDING LINE /GWC2500CH-01

**Standard Configuration** Line wire auto.alignment, Cross wire pre-loading hopper, Main welding machine, Servo motor pull mesh, Auto.bending, Auto.mesh output, Auto.mesh stacker, Industrial chiller

**Optional Configuration** Mesh support shelf  Line wire supporting frame  Mesh stacker cart  Air compressor  IF welding system

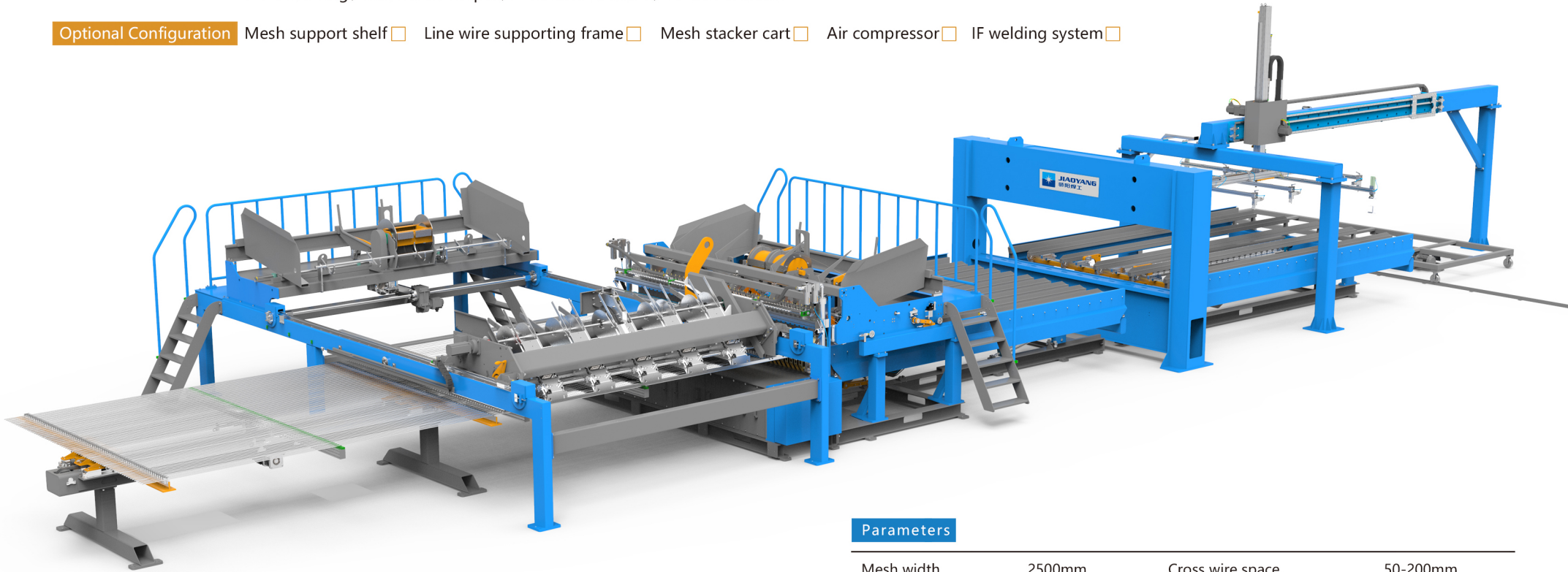

## Parameters

Mesh width	2500mm	Cross wire space	50-200mm
Number of electrodes	51	Cross wire feeding	Precut
Transformer	125KVA×13	Tolerance of diagonal line	±2mm(when 2m length)
Wire diameter	3-6mm	Welding material	Low carbon steel wire
Welding speed	60-80times/min	Finished mesh	Panel 3m
Line wire feeding	Precut	Line wire space	50-200mm



Scan QR code, to watch product working video

# DOUBLE WIRE FENCE MESH WELDING LINE / GWC3000CH-03

**Standard Configuration** Line wire supporting frame, Cross wire pre-loading hopper, Main welding machine, Servo motor pull mesh

**Optional Configuration** Auto.bending  Line wire auto.alignment and feeding  Auto.mesh gripper and stacker   
Mesh stacker cart  Mesh output frame  Air compressor  IF welding system

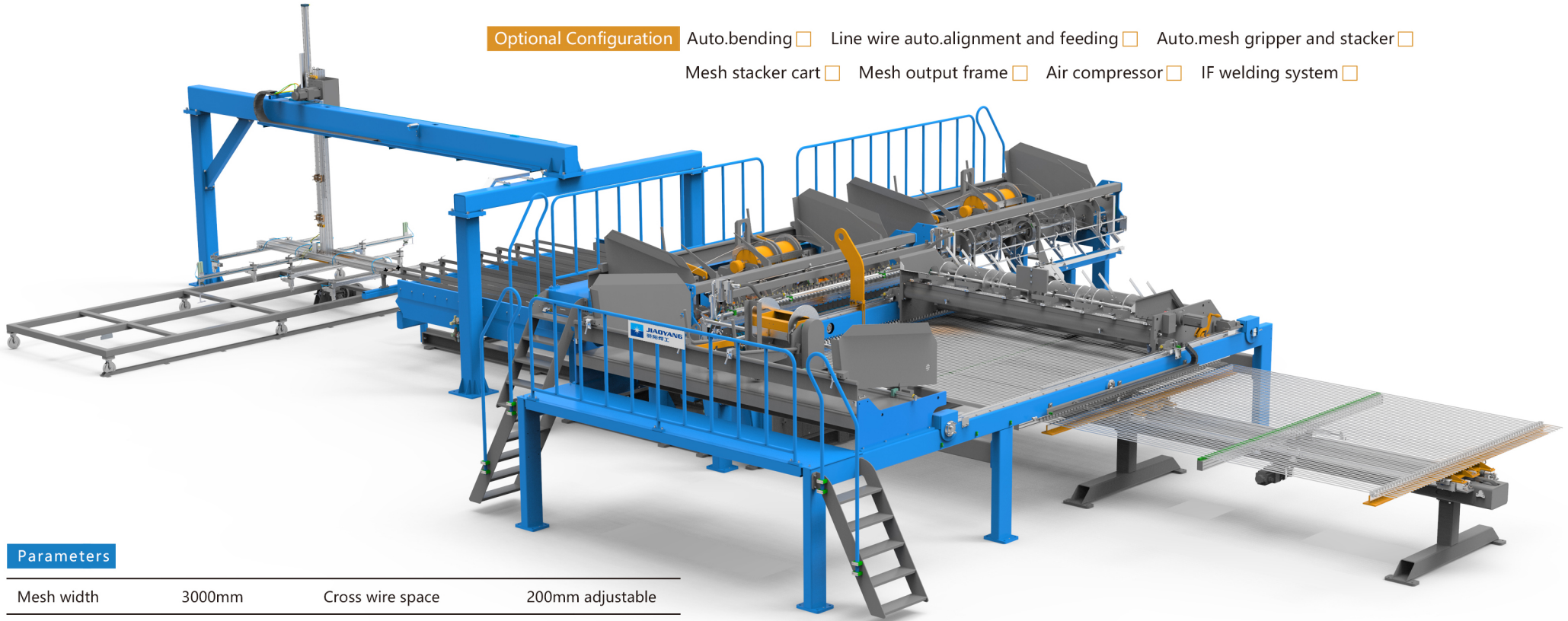

## Parameters

Mesh width	3000mm	Cross wire space	200mm adjustable
Number of electrodes	61	Cross wire feeding	Precut
Transformer	350KVA×8	Tolerance of diagonal line	±2mm(when 2m length)
Wire diameter	8+6+8; 6+5+6	Welding material	Low carbon steel wire
Welding speed	60times/min	Finished mesh	Panel 3m
Line wire feeding	Precut	Line wire space	50mm



Scan QR code, to watch product working video

# ANTI CLIMB FENCE MESH WELDING LINE / GWC3000CH-02

**Standard Configuration** Line wire supporting frame、 Cross wire pre-loading hopper、 Main welding machine、 Servo motor pull mesh

**Optional Configuration** Auto.bending  Line wire auto.alignment and feeding  Auto.mesh gripper and stacker  Mesh stacker cart   
Mesh output frame  Air compressor  IF welding system

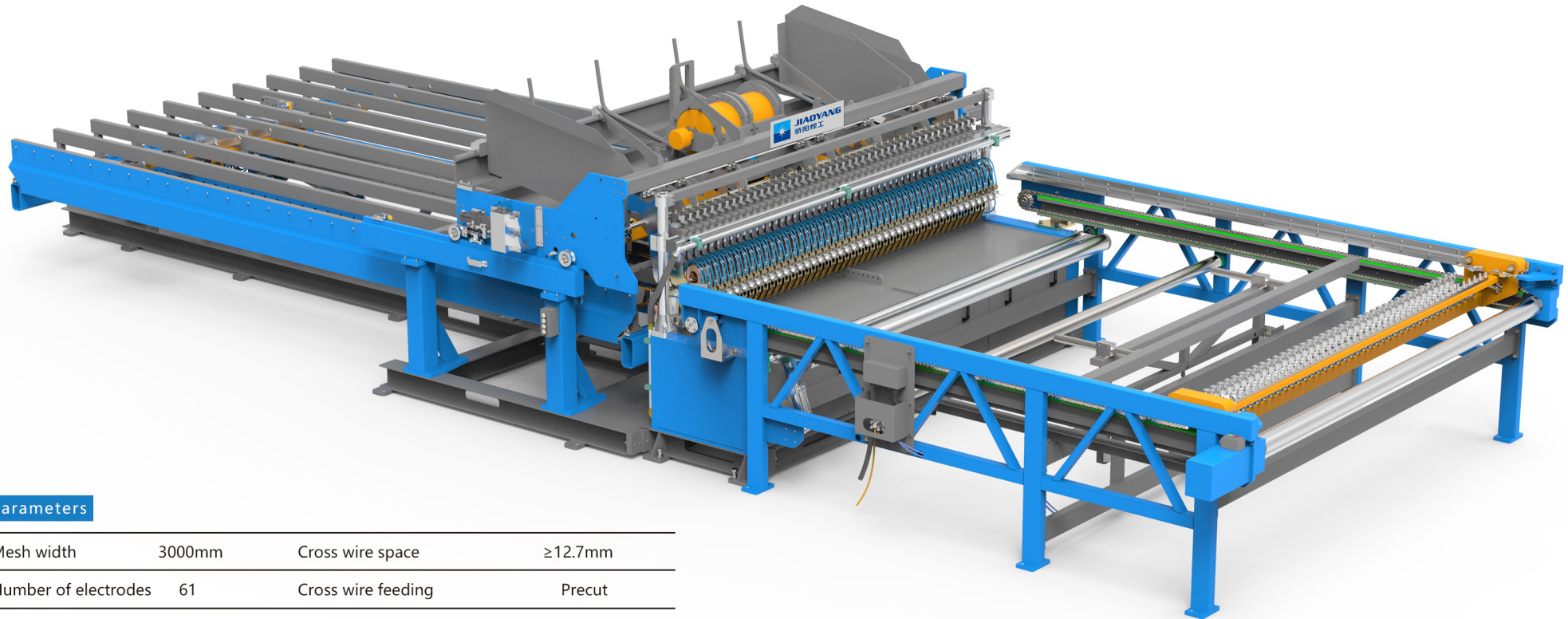

## Parameters

Mesh width	3000mm	Cross wire space	≥12.7mm
Number of electrodes	61	Cross wire feeding	Precut
Transformer	125KVA×16	Tolerance of diagonal line	±2mm(when 2m length)
Wire diameter	3-6mm	Welding material	Low carbon steel wire
Welding speed	60-80times/min	Finished mesh	Panel 3m
Line wire feeding	Precut	Line wire space	≥50mm



Scan QR code, to watch product working video

# FENCE MESH WELDING LINE/GWC-B1-01

### Standard Configuration

Line wire supporting frame, Main welding machine, cross wire hopper, Servo motor pull mesh, Ladder

### Optional Configuration

Line wire feeding cart  Simple water cooling chiller  Ladder with platform for hopper

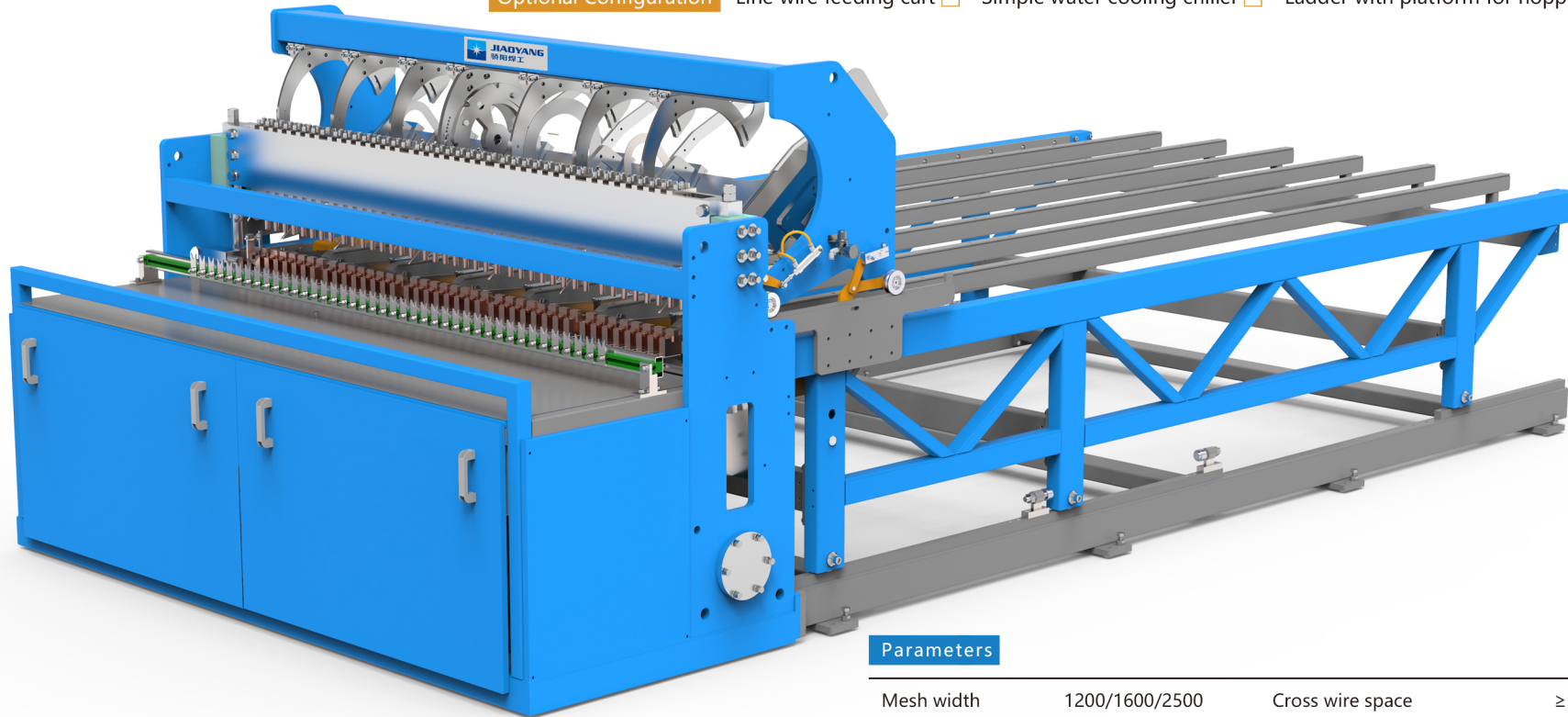

### Parameters

Mesh width	1200/1600/2500	Cross wire space	≥50mm
Number of electrodes	24/32/48	Cross wire feeding	Precut≥600mm
Transformer	125KVA×3/4/6	Tolerance of diagonal line	±2mm(when 2m length)
Wire diameter	3-5mm	Welding material	Black wire, galvanized wire
Welding speed	60-80times/min	Finished mesh	Panel
Line wire feeding	Precut	Line wire space	50-200mm



# STORAGE SHELVES MESH WELDING LINE/GWC1000ZG-01

Scan QR code, to watch product working video

**Standard Configuration** Line wire supporting frame、 Main welding machine、 cross wire hopper、 Servo motor pull mesh、 Ladder

**Optional Configuration** Line wire feeding cart  Simple water cooling chiller  Ladder with platform for hopper

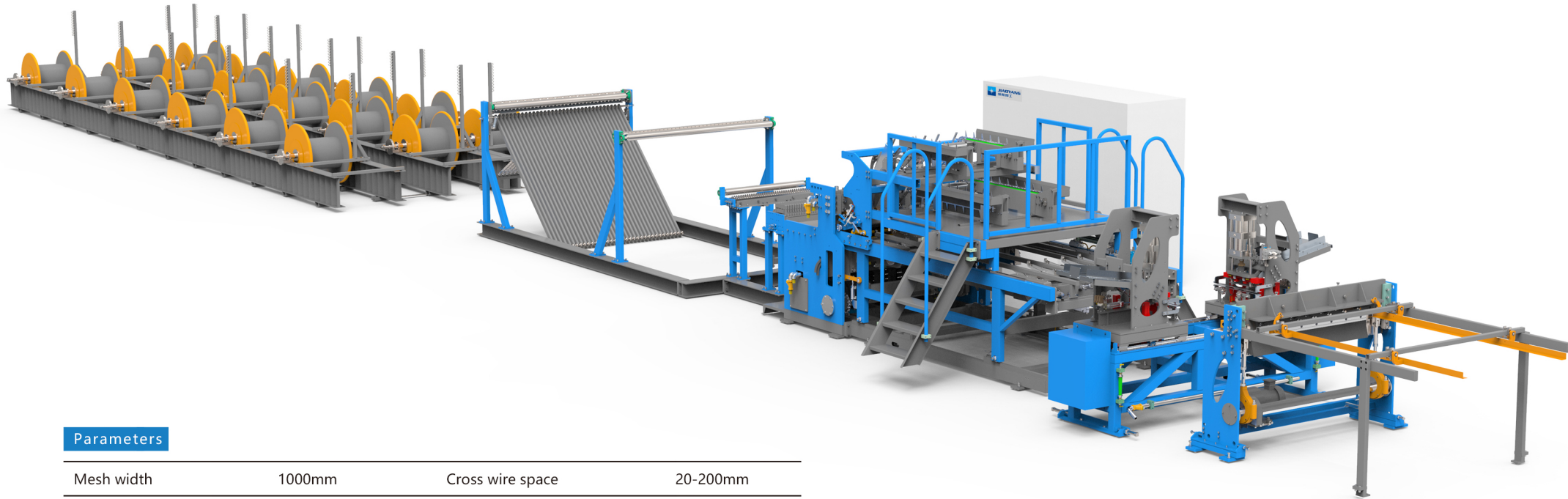

## Parameters

Mesh width	1000mm	Cross wire space	20-200mm
Number of electrodes	34	Cross wire feeding	Precut
Transformer	IF180KVA×5+2	Tolerance of diagonal line	±2mm(when 2m length)
Wire diameter	3+6mm(6mm for opposite side)	Welding material	Black wire, galvanized wire
Welding speed	60times/min	Finished mesh	Panel
Line wire feeding	Precut	Line wire space	24-27mm



## STORAGE CAGE & CABLE TRAY MESH WELDING LINE

Scan QR code, to watch product working video

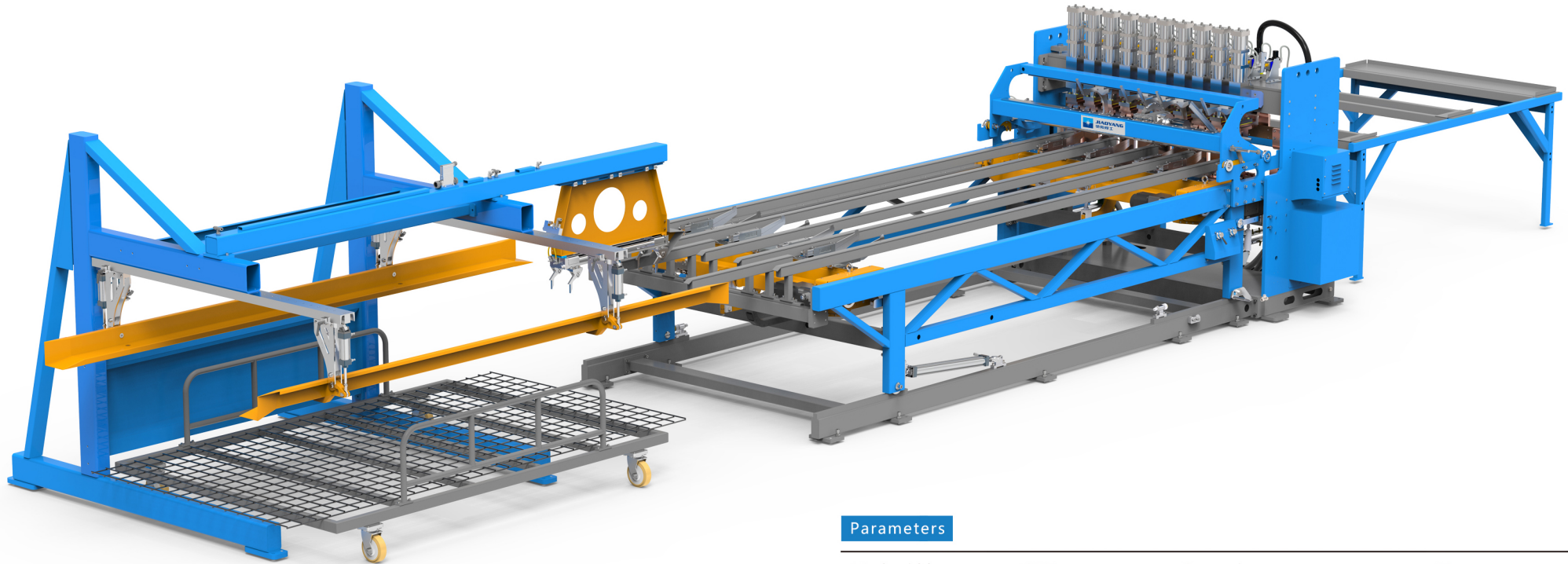

### Parameters

Mesh width	≤1500mm	Cross wire space	50mm
Number of electrodes	31	Cross wire feeding	Precut
Transformer	1F180KVA×2	Tolerance of diagonal line	±2mm(when 2m length)
Wire diameter	3-6mm	Welding material	Black wire, stainless steel wire
Welding speed	15-20times/min	Finished mesh	Panel
Line wire feeding	Precut	Line wire space	50-200mm





# WIRE STRAIGHTENING AND CUTTING MACHINE GTQ2/3.5&GTQ3/6&GTQ4/8&GTQ6/12

Scan QR code, to watch product working video

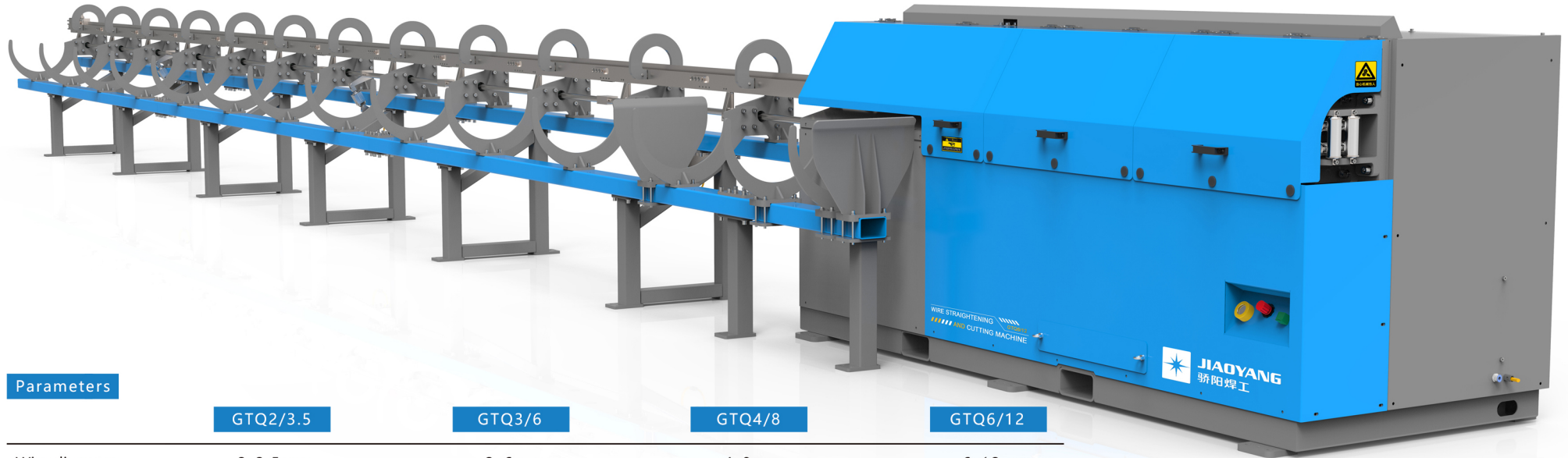

## Parameters

	GTQ2/3.5	GTQ3/6	GTQ4/8	GTQ6/12
Wire diameter	2-3.5mm	3-6mm	4-8mm	6-12mm
Working speed	50-70m/min	110m/min	110m/min	130mm/min
Wire straightness	≤2mm/m	≤2mm/m	≤2mm/m	≤2mm/m
Wire type	coil	coil	coil	coil
Cutting length	0.3-3m	0.5-6m	0.5-6m	0.8-6m
Cutting method	Eccentric shear	Servo cutting	Servo cutting	Servo cutting
Wire material	Low carbon steel wire,galvanized wire			
Wire pressure	Mechanical	Pneumatic	Pneumatic	Mechanical
Cutting tolerance	±0.2mm/m	±0.2mm/m	±0.2mm/m	±0.2mm/m
Total power capacity	4KW	10.5KW	18KW	34KW
Power supply	380V50HZ	3P380V50HZ	3P380V50HZ	3P380V50HZ



Scan QR code, to watch product working video

# 3D FENCE BENDING MACHINE / P TYPE FENCE WELDING MACHINE



Scan QR code, to watch product working video

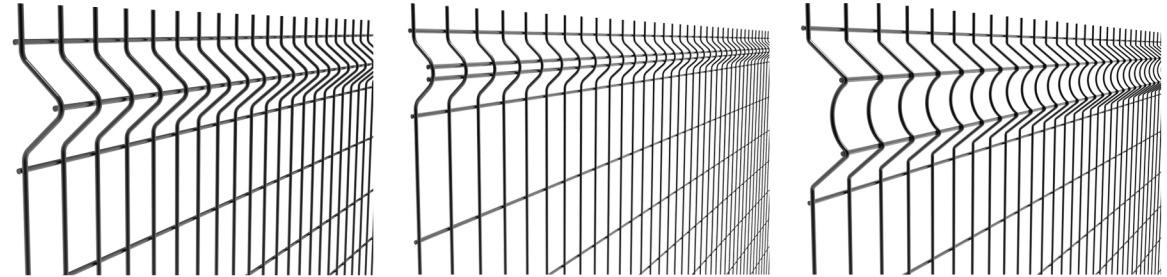
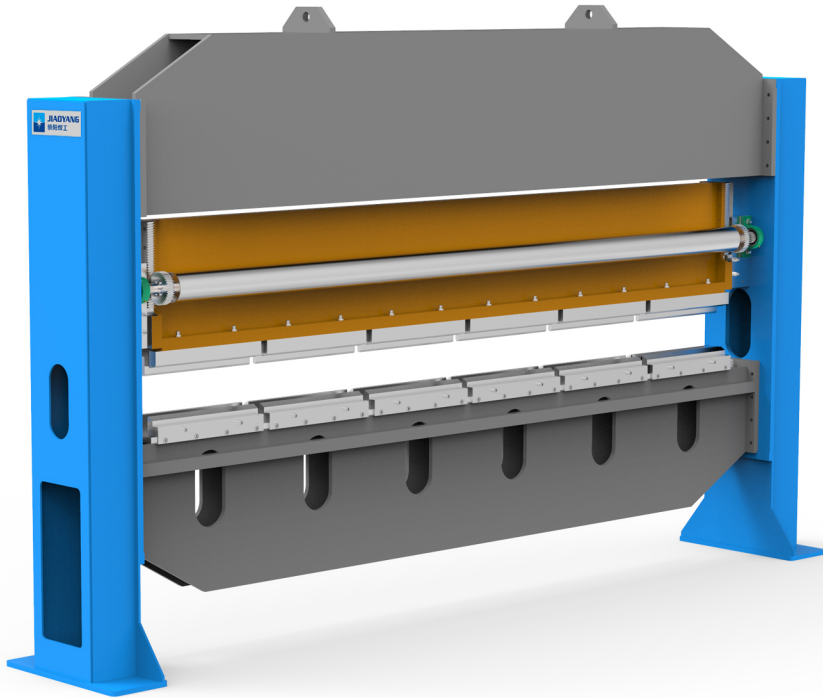

### 3D FENCE BENDING MACHINE PARAMETERS

Wire diameter	6mm	Bending width	3200mm
Bending speed	8times/min	Grease pump flow	25ml/min
Power supply	380V50HZ	Total power	7.5KW
Overall dimension	3.5×1.3×2.2m	Weight	3.7T

### P TYPE FENCE WELDING MACHINE PARAMETERS

Wire diameter	6mm	Bend width	3000mm
Max.bend angle	120°	Bend power	Hydraulic
Max.bend capacity	61pcs when 6mm	Min.space	50mm
Power supply	380V50HZ	Total power	7.5KW
Overall dimension	3.2×1.2×1m	Weight	1.3T

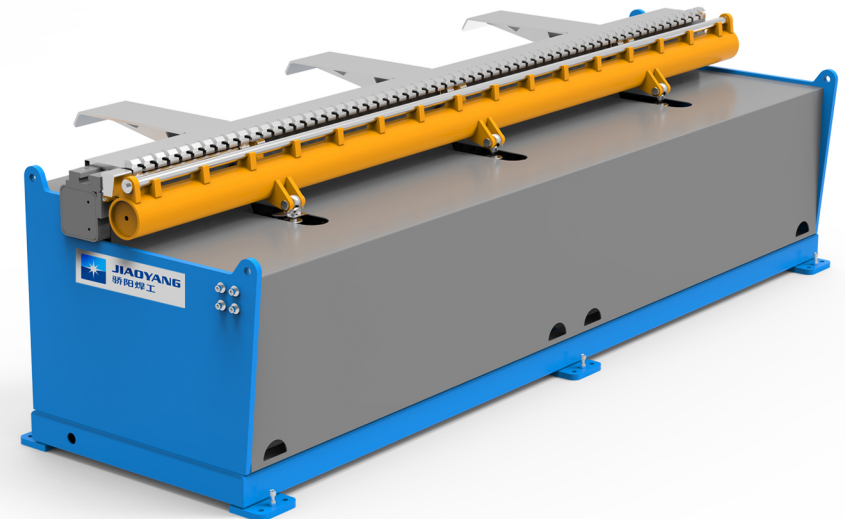



**河北骄阳焊工有限公司**  
**Jiaoyang welding industries hebei co.,ltd**

Add: NO.28 WEIER ROAD , EASTERN INDUSTRIAL ZONE,ANPING COUNTY,  
HEBEI PROVINCE,CHINA,053600

Tel: +86-318-7063110

Fax: +86-318-7800251

E-mail: joy@jiaoyangen.net

地址：河北省安平县工业园东区纬二路28号

营销部

电话：0318-7063097

传真：0318-7800251

售后服务

电话：0318-8065001

0318-7063093

网址：www.jiaoyang.net

由于我们的产品不断改进创新，因此产品结构参数及颜色可能与本样本有出入，请以实际产品为准，敬请谅解。

